

This Guide to Quantities is only applicable to Data Sheets D160.

Specifications and Quantities

The specifications below and overleaf detail the maximum and minimum capacities for the track systems recommended. Panels are hinged together to form units of up to seven full panels and one half panel hinged to a post. Openings can be covered by units 'floating' to either side of the opening. 'Floating' units consist of five or seven full panels and must include a guide.

If the panel weight is unknown, the weight can be calculated using the chart in Section 'A'. Having calculated the weight, use the information below to select the appropriate track system and quantities for the unit or units required to cover the opening width.

Specification for Individual Panels

Track System	Centrefold 75
Refer to Data Sheet	D160
Max Panel Height	3300mm
Max Panel Weight	75kg
Max Panel Width	1000mm
Min Panel Thickness	40mm
Max Number of Panels	7 ½ each direction

1 ½ Panel Unit Hinged to Post

	Quantities	Product Codes
Track	See data sheet D155C	250
Bracket (face fix)	See data sheet D155C	1SS/250
Hanger	1	61/4HN
Hinges	6*	404/3
Guide (optional)	1	106RB/94
Channel (optional)	See data sheet D155C	94A, 94B, 94P & 94PA
Flush Pulls	2	401
Flush Bolt	2	456

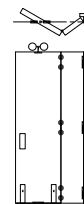

*For Panels exceeding 3000mm high, increase to 9

2 ½ Panel Unit Hinged to Post Inc. Access Door

	Quantities	Product Codes
Track	See data sheet D155C	250
Brackets, (face fix)	See data sheet D155C	1SS/250
Hanger	1	61/4HN
Hinges	9*	404/3
Guide (optional)	1	106RB/94
Channel (optional)	See data sheet D155C	94A, 94B, 94P & 94PA
Flush Pull	3	401
Flush Bolts	3	456

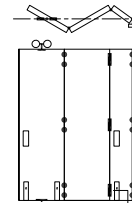

*For Panels exceeding 3000mm high, increase to 12

3 ½ Panel Unit Hinged to Post

	Quantities	Product Codes
Track	See data sheet D155C	250
Bracket (face fix)	See data sheet D155C	1SS/250
Hanger	2	61/4HN
Hinges	12*	404/3
Guides	2	106RB/94
Channel	See data sheet D155C	94A, 94B, 94P & 94PA
Flush Pulls	3	401
Flush Bolts	3	456

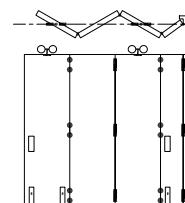

*For Panels exceeding 3000mm high, increase to 16

4 ½ Panel 'Floating' Unit

	Quantities	Product Codes
Track	See data sheet D155C	250
Bracket (face fix)	See data sheet D155C	1SS/250
Hangers	2	61/4HN
Hinges	15*	404/3
Guides	2	106RB/94
Channel	See data sheet D155C	94A, 94B, 94P & 94PA
Flush Pulls	4	401
Flush Bolts	4	456

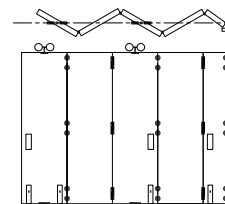

*For Panels exceeding 3000mm high, increase to 20

5 Panel Unit 'Floating' to either side

	Quantities	Product Codes
Track	See data sheet D155C	250
Bracket (face fix)	See data sheet D155C	1SS/250
Hangers	3	61/4HN
Hinges	12*	404/3
Guides	3	106RB/94
Channel	See data sheet D155C	94A, 94B, 94P & 94PA
Flush Pulls	4	401
Flush Bolts	4	456

*For Panels exceeding 3000mm high, increase to 16

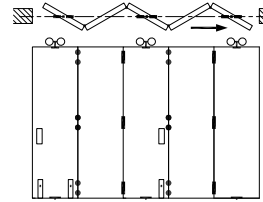

5 ½ Panel Unit pivoted to one side

	Quantities	Product Codes
Track	See data sheet D155C	250
Bracket (face fix)	See data sheet D155C	1SS/250
Hangers	3	61HN
Hinges	18*	404/3
Guides	3	106RB/94
Channel	See data sheet D155C	94A, 94B, 94P & 94PA
Flush Pulls	4	401
Flush Bolts	4	456

*For Panels exceeding 3000mm high, increase to 24

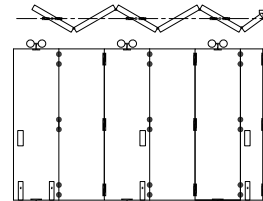

6 ½ Panel Unit pivoted to one side

	Quantities	Product Codes
Track	See data sheet D155C	250
Bracket (face fix)	See data sheet D155C	1SS/250
Hangers	3	61/4HN
Hinges	21*	404/3
Guides	3	106RB/94
Channel	See data sheet D155C	94A, 94B, 94P & 94PA
Flush Pulls	5	401
Flush Bolts	5	456

*For Panels exceeding 3000mm high, increase to 28

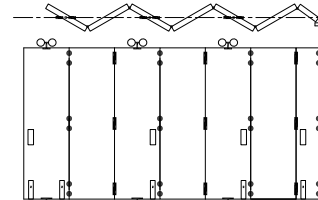

2 Additional Panels to Increase 5 ½ or 5 Panel Units to 7 ½ or 7 Panel Units

	Quantities	Product Codes
Hanger	1	61/4HN
Hinges	6*	404/3
Guide	1	106RB/94
Flush Pull	1	401
Flush Bolt	1	456

*For Panels exceeding 3000mm high, increase to 8

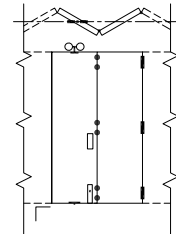

Track, Bracket and Channel Quantities

From the table below, choose the quantities of applicable track, bracket and channel.

Track and Channel

Choose sufficient track and channel to cover the overall opening width. If a 'floating' unit is required to slide clear of the opening, then sufficient track and channel is required to cover the widths of the stacking bay and the opening.

Bracket Spacing (Face Fix)

Place a bracket at 50mm in from both ends on each track, on each track used. Install next bracket 100mm in from the first bracket on the end which panels will pivot from. If using 5 1/2 panels or more, install another bracket 100mm in from the second bracket. Then install a bracket at approximately 400mm intervals.

Opening Width	Track Length	Bracket Quantity	Channel lengths
2000 (1 unit of 2 1/2 panels)	1 x 2000	7	1 x 2000
3000 (1 unit of 3 1/2 panels)	1 x 3000	9	1 x 3000
4000 (1 unit of 4 1/2 panels)	1 x 4000	12	1 x 4000
5000 (1 unit of 5 1/2 panels)	1 x 5000	15	1 x 5000
6000 (1 unit of 5 1/2 panels)	1 x 6000	17	1 x 6000
7000 (1 unit of 7 1/2 panels)	1 x 3000 } 1 x 4000 }	20	1 x 3000 } 1 x 4000 }
8000 (2 units of 4 panels)	2 x 4000	24	2 x 4000

If using two units which pivot from both sides of the opening, repeat the 100mm fixing point on both ends of the track

If using floating panels, increase fixing points in location where panels will be stacked in the open position.

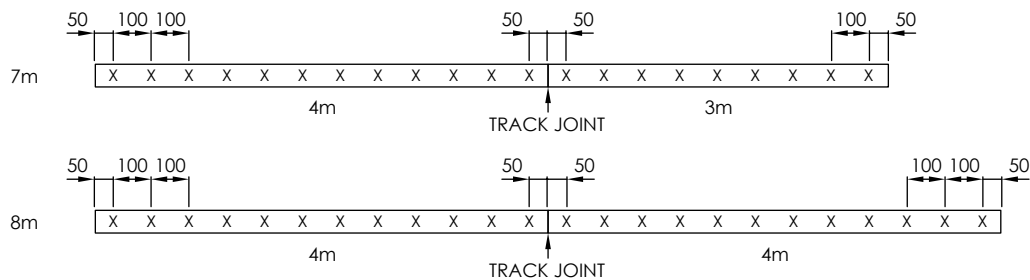

X = BRACKET POSITION APPROX. 400mm SPACINGS UNLESS OTHERWISE SPECIFIED



Application

Suitable for residential or commercial centre folding partitions.

Panels are hung centrally under the lintel and can fold to one or both sides of the opening.

To cover any width of opening, any number of folding units can be used.

Panel Specification

Track System:	Centrefold 75
For Individual Panels:	
Max Panel Height	3300mm
Max Panel Weight	75kg
Max Panel Width	1000mm
Min Panel Thickness	40mm

A guide system across the floor must be used on units of 3 and a half panels or more.

Folding units of up to seven full panels and one half panel can be hinged to a post.

Floating units consist of five or seven full panels.

Access should be through either a separate door hinged to a post or a door hinged in one of the folding panels.

Panels should be constructed to provide secure fitting for hangers, hinges and guides and can be flush, panelled or glazed.

Hardware Specification

Track:	250
Material	Aluminium, Mill or Clear Anodised
Standard Lengths	2000mm, 3000mm, 4000mm and 6000mm

Bracket:	
Bracket 316 Stainless Steel	1SS/250

Brackets located close together at the pivot end of the track with other brackets at 400mm centres.

Hangers:	61/4HN
-----------------	--------

Hangers are fitted with nylon tyre wheels on ball race bearings. Vertical adjustment is simple and positive.

Guide:	106RB/94
---------------	----------

Guide incorporates a precision bearing. All steel parts to hangers and guides are stainless steel

Hinges:	
Butt hinge	404/2S
Stainless steel hinge, 76x63mm	

Butt hinge	404/3S
Stainless steel hinge, 101x76mm	

Channels:	
Aluminium	94A
Polypropylene & Aluminium	94PPA
Finish	Mill or clear anodised
Brass	94B
Standard Lengths	2000mm, 3000mm, 4000mm and 6000mm

Accessories:	
Flush Pulls	401
Flush Bolts	456

Flush bolts and flush pulls are available in (PVDB) PVD Brass, (SN) Satin Nickel & (PN) Polished Nickel

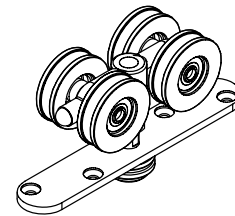

No. 61/4HN
HANGER

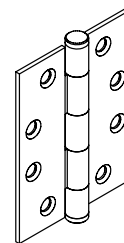

No. 404/3S
HINGE

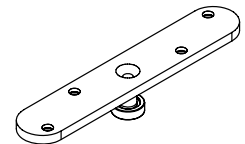

No. 106RB/94
GUIDE

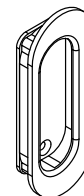

No. 401
FLUSH PULL

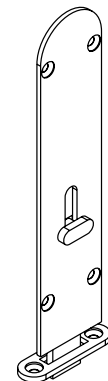

No. 456R
FLUSH BOLT

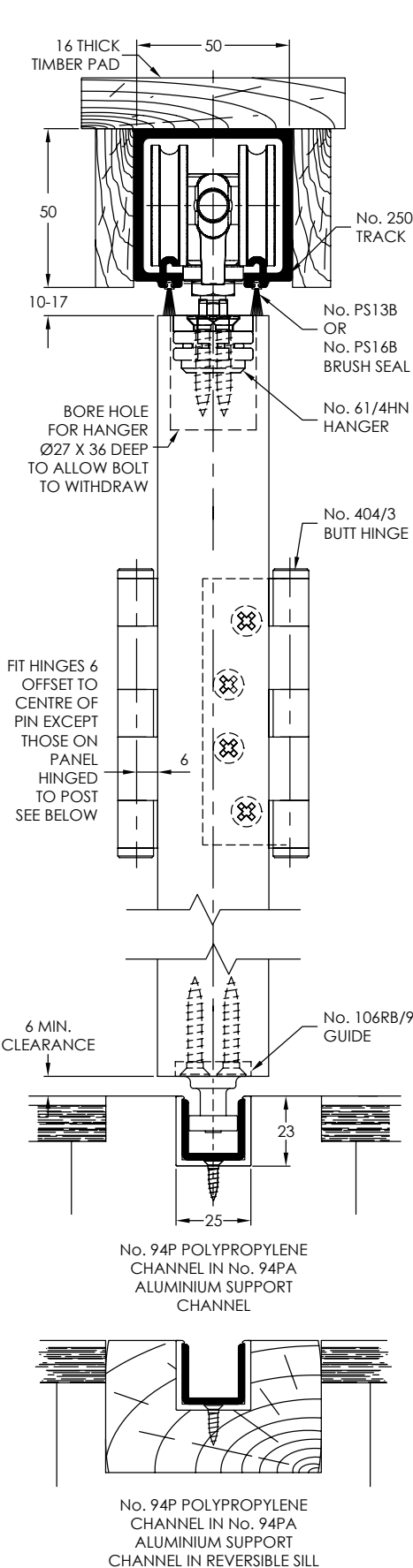

ALTERNATIVE BRACKET FIX

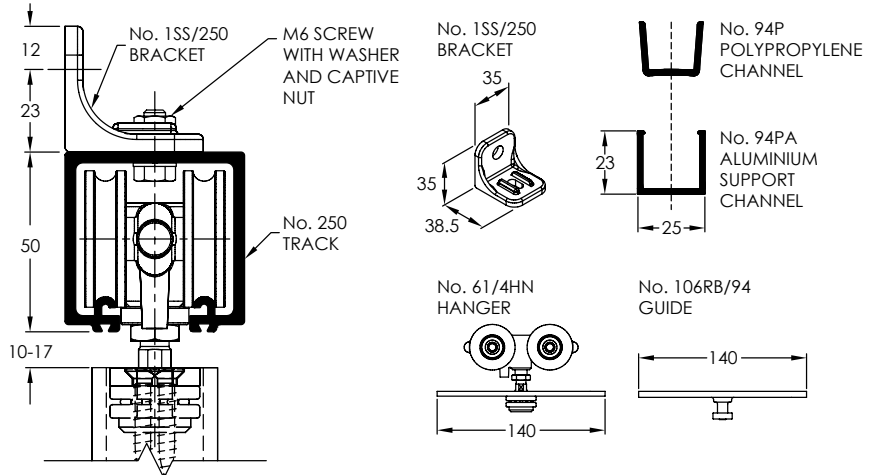

FORMULA FOR PANEL WIDTH CALCULATIONS

HINGE PIN TO HINGE PIN CENTRES	=	ALL PANELS ARE THE SAME WIDTH
FULL PANEL WIDTH	=	$\frac{\text{WIDTH BETWEEN REBATED POSTS} + \left(\frac{1}{2} \text{ PANEL THICKNESS} \times \text{No. OF PANELS HINGED TO POST}\right)}{\text{NUMBER OF PANELS}}$
PANEL HINGED TO A POST	=	$\left(\frac{1}{2} \text{ FULL PANEL WIDTH} - \frac{1}{2} \text{ PANEL THICKNESS}\right) - \text{PANEL CLEARANCE}$

FOR EXAMPLE:
 2 UNITS OF 3 1/2 PANELS
 PANEL THICKNESS = 44mm
 2 PANELS HINGED TO OPPOSITE POSTS
 OVERALL BETWEEN POSTS = 6186
 2MM CLEARANCE

FULL PANEL WIDTH = $\frac{(6186 + 22 + 22)}{7} (= 890) - 2 = 888$

PANELS HINGED TO POST = $(888 / 2) - (44 / 2) - 2 = 420$

HINGE POSITIONING

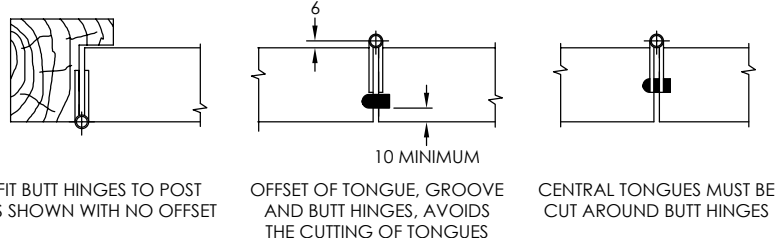

CONFIGURATIONS

PLAN 1

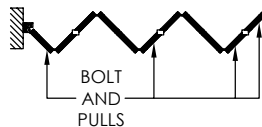

5 1/2 PANELS HINGED TO POST AS PLAN 1

PLAN 2

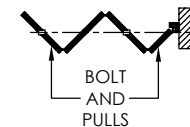

3 1/2 PANELS HINGED TO POST AS PLAN 2

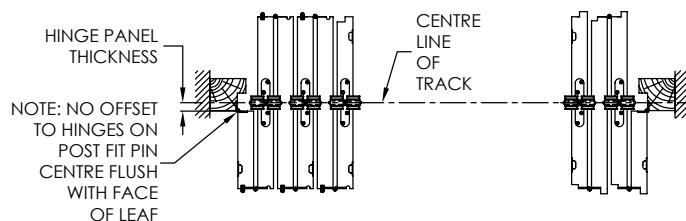

TONGUE AND GROOVE JOINTS
 THESE JOINTS, WITH HARDWOOD TONGUES ARE RECOMMENDED

REBATED JOINTS
 IF REBATING IS PREFERRED IT MUST BE TO LAYOUT ABOVE