

# Brio® Shutterfold 25, Screenfold 25 & Louvrefold 25 - Guide to Quantities

For Top Hung Exterior Folding Shutters, Screens and Louvred Panels

This Guide to Quantities is only applicable to Data Sheets E40, E50 & E60.

## Specifications and Quantities

The specifications below and over leaf detail the maximum and minimum capacities for the track systems recommended. Panels are hinged together to form either one or two units of up to six panels each, with each unit pivoted to one side of the opening. Openings can be covered by units of four or six 'floating' panels which are not hinged to the opening.

If the panel weight is unknown, the weight can be calculated using the chart in Section 'A'. Having calculated the weight, use the information below to select the appropriate track system and quantities for the unit or units required to cover the opening width.

### Specification for Individual Panels

Track System	Shutterfold 25	Screenfold 25	Louvrefold 25
Refer to Data Sheet	E40	E50	E60
Max Panel Height	2400mm	2400mm	2400mm
Max Panel Weight	25kg	25kg	25kg
Max Panel Width	900mm	900mm	900mm
Recommended Panel Thickness	35-50mm	19mm	35-50mm
Max Number of Panels	6 each direction	6 each direction	6 each direction

### 2 Panel Unit

	Quantities	Product Codes		
Track	1	100-A20	100-A20	100-A20
Pivot Set	1	21EPNC	21EPB	21EPB-A
Hinge	3	282SS		
Screen Hinges	2		135SS	135SS
Screen Hinges Handle	1		136SS	136SS
Hanger - End	1	57SS/EN	53SSEN	52EN-A
Guide	1		113RB/94	21ER-A
Flush Bolt - Bottom	1	360E	FFB85SS	FFB85SS
Flush Pull	1	401		
Channel	1		94A-A20	94A-A20

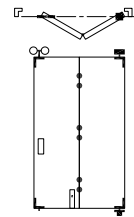

### 3 Panel Unit

	Quantities	Product Codes		
Track	1	100-A30	100-A30	100-A30
Pivot Set	1	21EP	21EPB	21EPB-A
Hinge	6	282SS		
Screen Hinges	5		135SS	135SS
Screen Hinge Handle	1		136SS	136SS
Hanger - Intermediate	1	57SS/EN	53SS/4EN	52EN/4-A
Guide	1		113RB/94	21ER-A
Flush Bolt - Bottom	1	360E	FFB85SS	FFB85SS
Flush Pull	2	401		
Channel	1	94PPA-A30	94A-A30	94A-A30

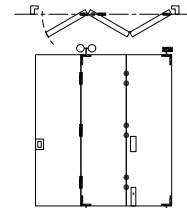

### 4 Panel Unit

	Quantities	Product Codes		
Track	1	100-A40	100-A40	100-A40
Pivot Set	1	21EP	21EPB	21EPB-A
Hinge	9	282SS		
Screen Hinges	7		135SS	135SS
Screen Hinge Handle	2		136SS	136SS
Hanger - Intermediate	1	57SS/EN	53SS/4EN	53EN/4-A
Hanger - End	1	57SS/EN	53SSEN	52EN-A
Guide	2	106E/94	113RB/94	21ER-A
Flush Bolt - Bottom	2	360E	FFB85SS	FFB85SS
Flush Pull	2	401		
Channel	1	94PPA-A40	94A-A40	94A-A40

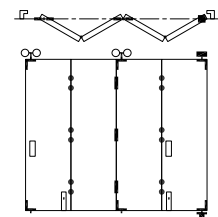

		<b>Shutterfold 25</b>	<b>Screenfold 25</b>	<b>Louvre-fold 25</b>
<b>4 Panel Unit 'Floating'</b>	<b>Quantities</b>	<b>Product Codes</b>		
Track	1	100-A40	100-A40	100-A40
Hinge	9	282SS		
Screen Hinges	7		135SS	135SS
Screen Hinge Handle	2		136SS	136SS
Hanger - Intermediate	1	57SS/EN	53SS/4EN	53EN/4-A
Hanger - End	2	57SS/EN	53SSEN	52EN-A
Guide	3	106E/94	113RB/94	21ER-A
Flush Bolt - Bottom	2	360E	FFB85SS	FFB85SS
Flush Pull	2	401		
Channel	1	94PPA-A40	94A-A40	94A-A40
<b>2+2 Panel Unit</b>	<b>Quantities</b>	<b>Product Codes</b>		
Track	1	100-A40	100-A40	100-A40
Pivot Set	2	21EP	21EPB	21EPB-A
Hinge	6	282SS		
Screen Hinges	4		135SS	135SS
Screen Hinge Handle	2		136SS	136SS
Hanger - End	2	57SS/EN	53SSEN	52EN-A
Guide	2	106E/94	113RB/94	21ER-A
Flush Bolt - Bottom	2	360E	FFB85SS	FFB85SS
Flush Pull	2	401		
Channel	1	94PPA-A40	94A-A40	94A-A40
<b>5 Panel Unit</b>	<b>Quantities</b>	<b>Product Codes</b>		
Track	1	100-A60	100-A60	100-A60
Pivot Set	1	21EP	21EPB	21EPB-A
Hinge	12	282SS		
Screen Hinges	10		135SS	135SS
Screen Hinge Handle	2		136SS	136SS
Hanger - Intermediate	2	57SS/EN	53SS/4EN	53EN/4-A
Guide	2	106E/94	113RB/94	21ER-A
Flush Bolt - Bottom	2	360E	FFB85SS	FFB85SS
Flush Pull	3	401		
Channel	1	94PPA-A60	94A-A60	94A-A60
<b>6 Panel Unit</b>	<b>Quantities</b>	<b>Product Codes</b>		
Track	1	100-A60	100-A60	100-A60
Pivot Set	1	21EP	21EPB	21EPB-A
Hinge	15	282SS		
Screen Hinges	12		135SS	135SS
Screen Hinge Handle	3		136SS	136SS
Hanger - Intermediate	2	57SS/EN	53SS/4EN	53EN/4-A
Hanger - End	1	57SS/EN	53SSEN	52EN-A
Guide	3	106E/94	113RB/94	21ER-A
Flush Bolt - Bottom	3	360E	FFB85SS	FFB85SS
Flush Pull	3	401		
Channel	1	94PPA-A40	94A-A40	94A-A40
<b>6 Panel Unit 'Floating'</b>	<b>Quantities</b>	<b>Product Codes</b>		
Track	1	100-A60	100-A60	100-A60
Hinge	15	282SS		
Screen Hinges	12		135SS	135SS
Screen Hinge Handle	3		136SS	136SS
Hanger - Intermediate	2	57SS/EN	53SS/4EN	53EN/4-A
Hanger - End	2	57SS/EN	53SSEN	52EN-A
Guide	4	106E/94	113RB/94	21ER-A
Flush Bolt - Top	3	360		
Flush Bolt - Bottom	3	360E	FFB85SS	FFB85SS
Flush Pull	3	401		
Channel	1	94PPA-A60	94A-A60	94A-A60

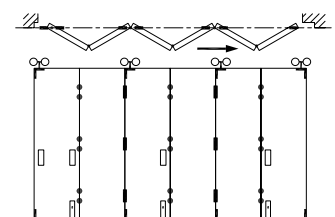
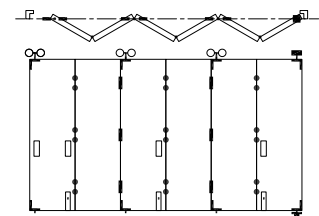
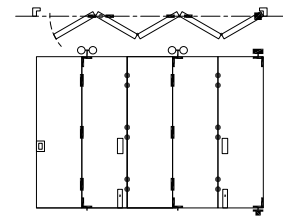
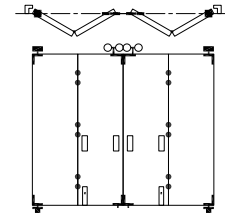
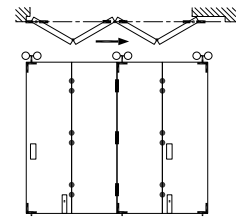

### Application

Designed to suit aluminium folding louvred panels, with all panels of equal width. Panels can fold to one or both sides of the opening.

Pivot hardware enables folding exterior screen to be designed using equal width panels with no cutting down of the panel adjacent to post.

All stainless steel hardware components are concealed within the aluminium door stile.

### Panel Specification

Track System:	Louvrefold 25
Max Panel Height	2400mm
Max Panel Weight	25kg
Max Panel Width	900mm
Panel Thickness	30mm

### Hardware Specification

<b>Track:</b>	100
Material	Aluminium, Clear Anodised
Standard Lengths	2000mm, 3000mm, 4000mm and 6000mm

<b>Bracket (Face Fix):</b>	
Bracket 316 Stainless Steel	1SS/250
Brackets located close together at the pivot end of the track with other brackets at 400mm centres.	

<b>Hanger Sets:</b>	
End Hanger	52EN-A
Intermediate Hanger	52EN/4-A
Stainless Steel hangers are fitted with nylon wheels on precision stainless steel ball race bearings. Vertical adjustment is simple and positive.	

<b>Pivot Sets:</b>	
Adjustable Top & Bottom Pivot	21EP-A

<b>Guide:</b>	
With Precision Stainless Bearing	21ER-A

<b>Hinge Sets:</b>	
Screen Hinge	135SS
Screen Hinge & Handle	136SS
Screen hinges are constructed from 304 Satin Stainless Steel	

<b>Channels:</b>	
Aluminium	94A
Finish	Aluminium, Mill or Clear Anodised
Standard Lengths	2000mm, 3000mm, 4000mm and 6000mm

<b>Accessories:</b>	
Barrel Bolt (bottom only)	FFB-85SS

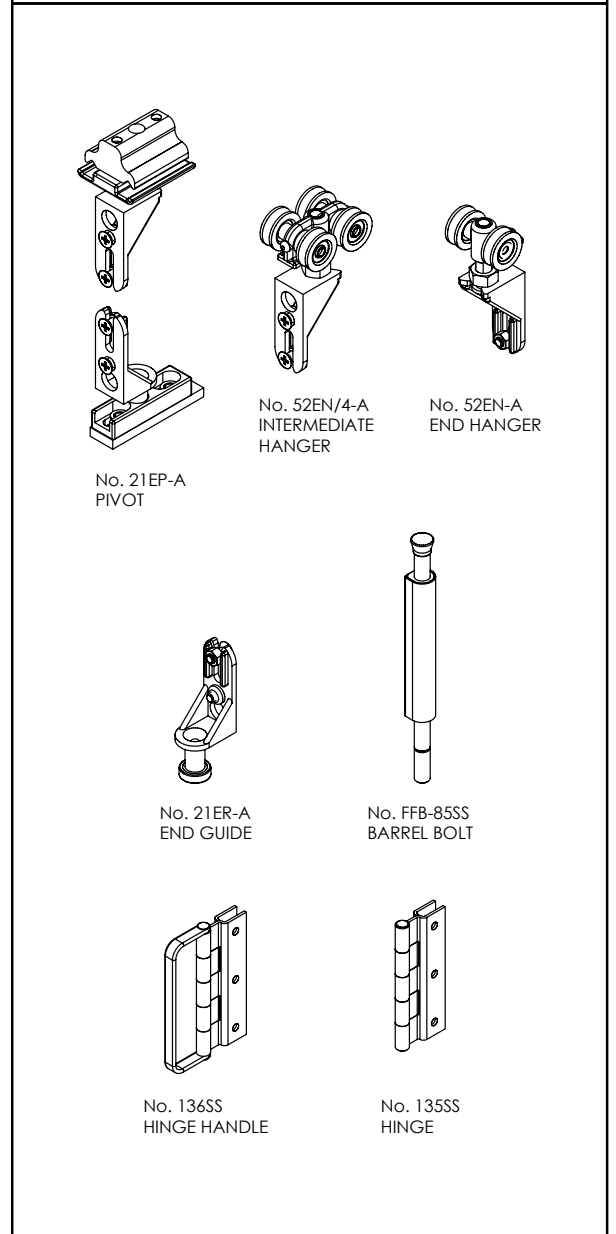
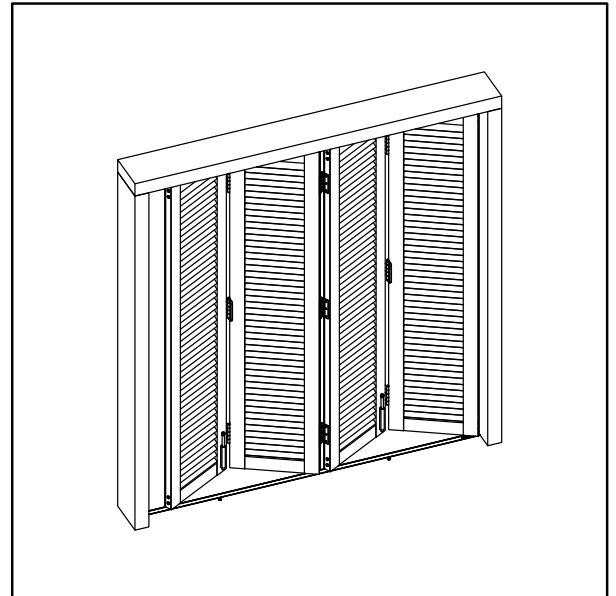

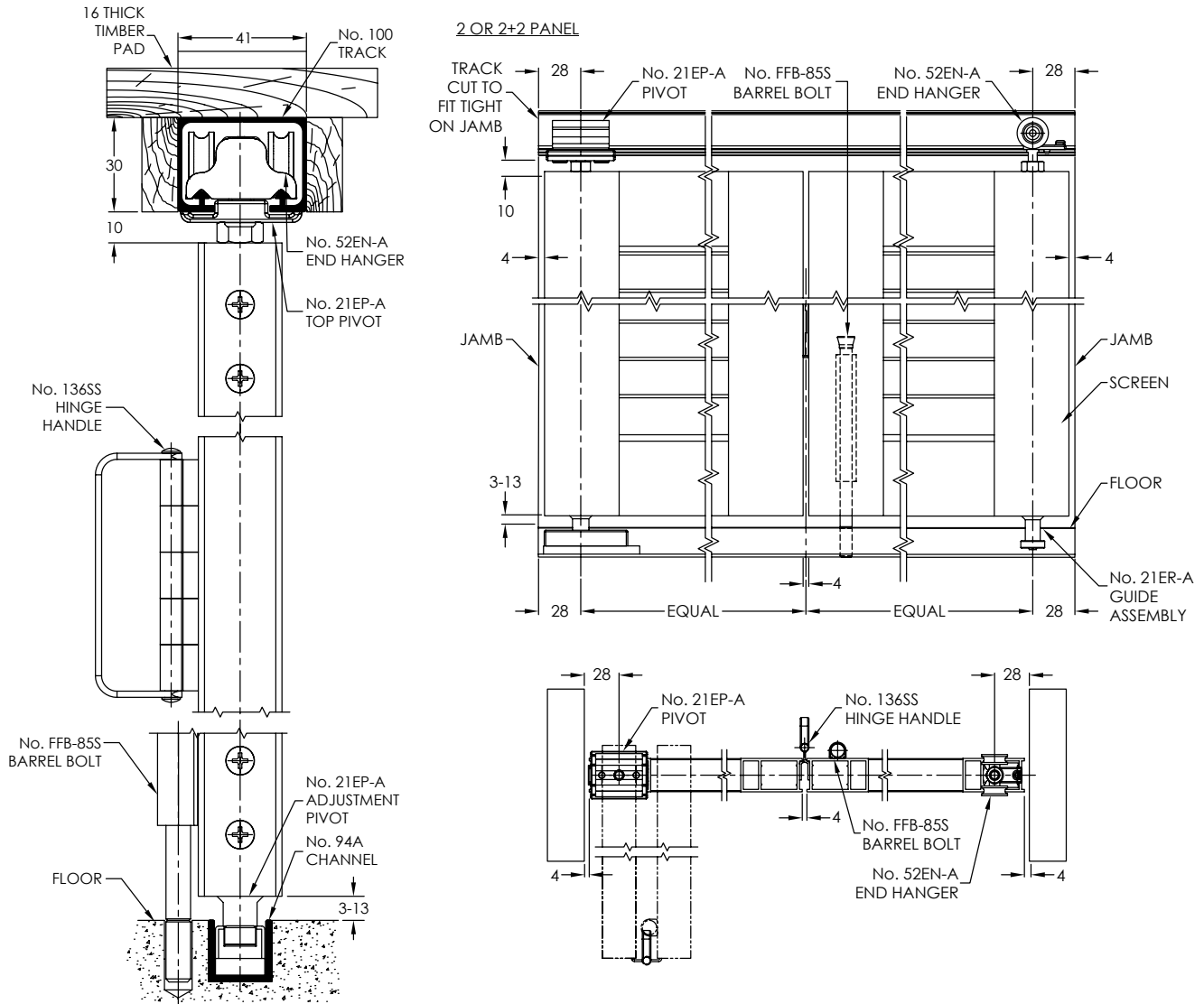

**4 PANEL**

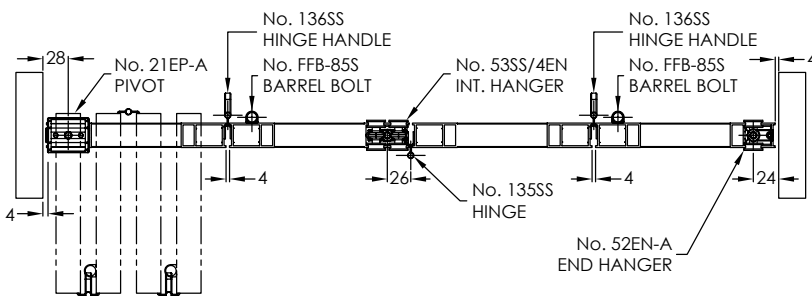

**6 PANEL**

