

Brio Weatherfold 4s 50F

Brio Australia
 P: +61 2 87186718
 W: brio.com.au
 E: brio.sales@allegion.com

Brio UK
 P: +44 191 2291224
 W: briouk.com
 E: brio.sales.uk@allegion.com

Brio USA
 P: +1 585 3195599
 W: briousa.com
 E: brio.sales.usa@allegion.com

Codes

B WS 1 - 50 S H SS ———— Finish: SS (Satin Stainless)
 Hinge Type: H Type Non-Mortice hinge, M Type Mortice hinge.
 Bearing Type: S (Stainless Steel Bearing)
 Load Capacity: 50kg (110lbs)panels
 Set No: 1 (Pivot Set), 2 (End Hanger Set), 4F (Intermediate Hanger Set),
 3 (Hinge Handle Set), 5 (Hinge Set), 6 (Offset Hinge Set),
 7 (Offset Hinge Handle Set)

Brio Weatherfold 4s

Sets. No finishes shown

BWS1F-50H

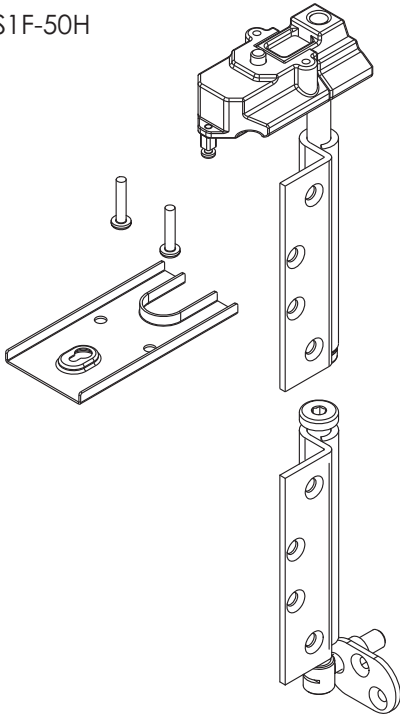

BWS2-50SH

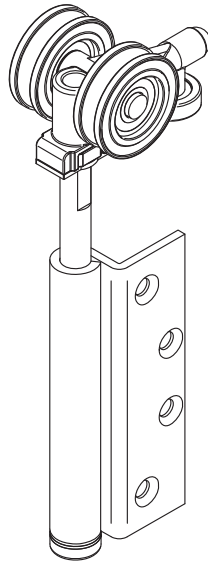

BWS2-50SM

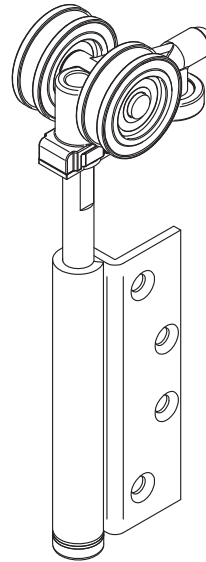

BWS4F-50SH

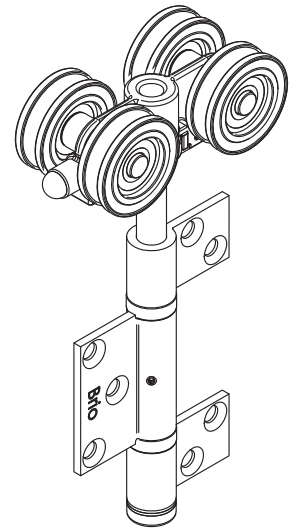

BW3-100H

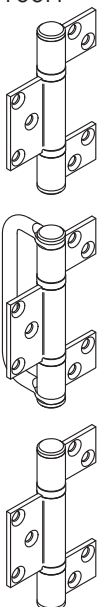

BW5-100H

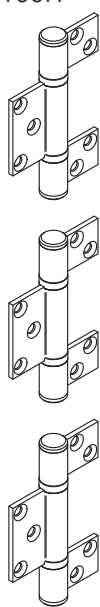

BW6-100H

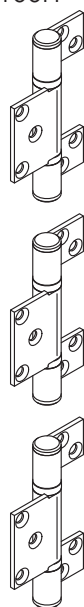

BW7-100H

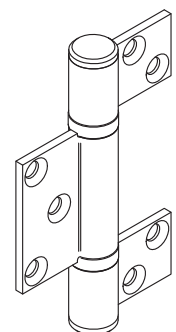
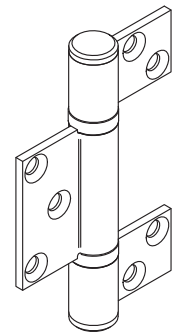
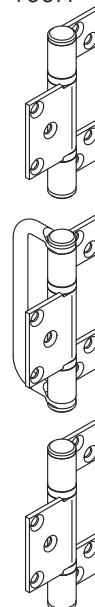

Door Hardware Set Orientation

FB = Flush Bolt, FP = Flush Pull, LK = Lock, left systems shown

OUTWARD OPENING (Max. 4 panels each way. Even panel quantities only.)

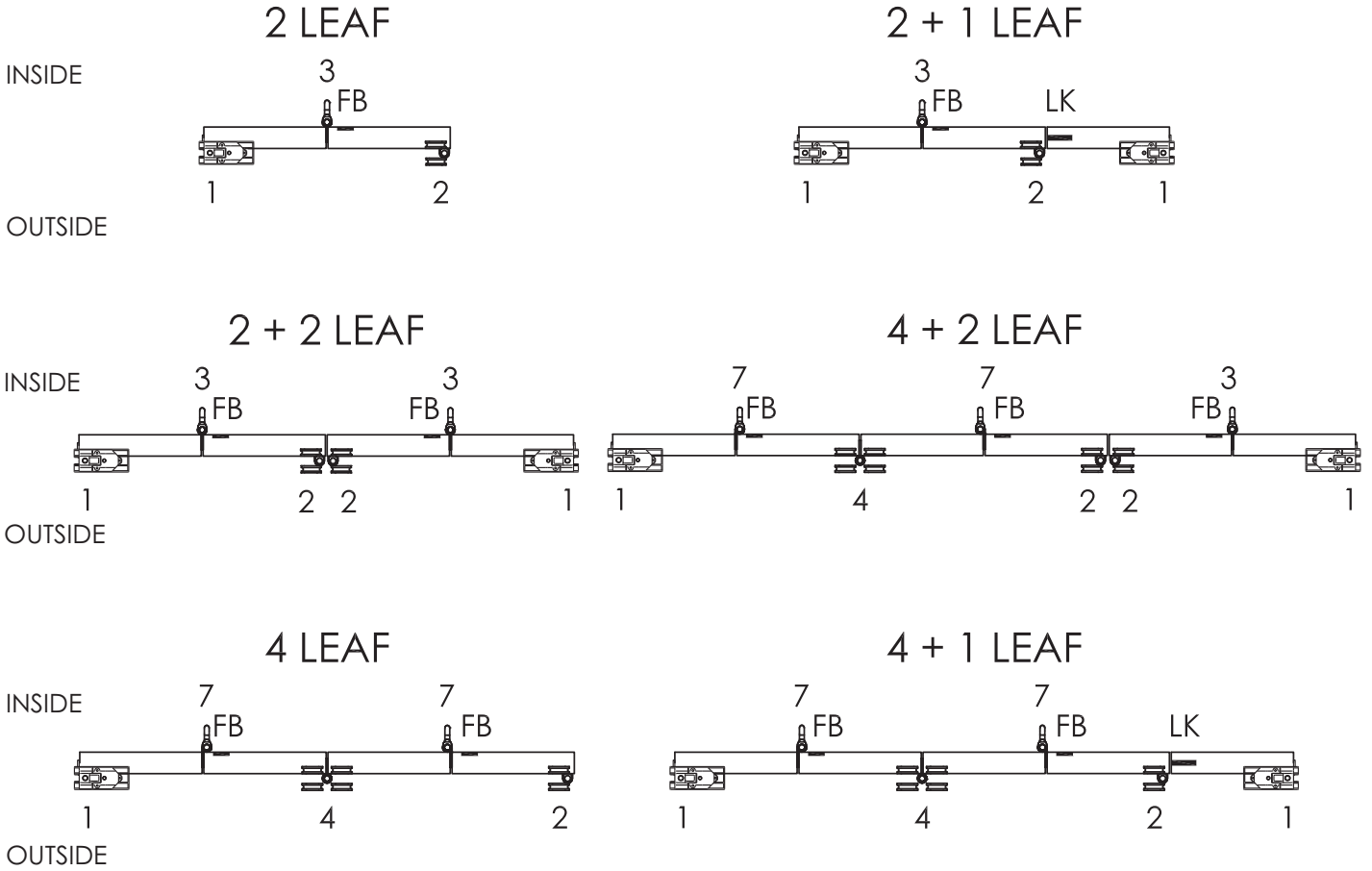

INWARD OPENING (Max. 4 panels each way. Even panel quantities only.)

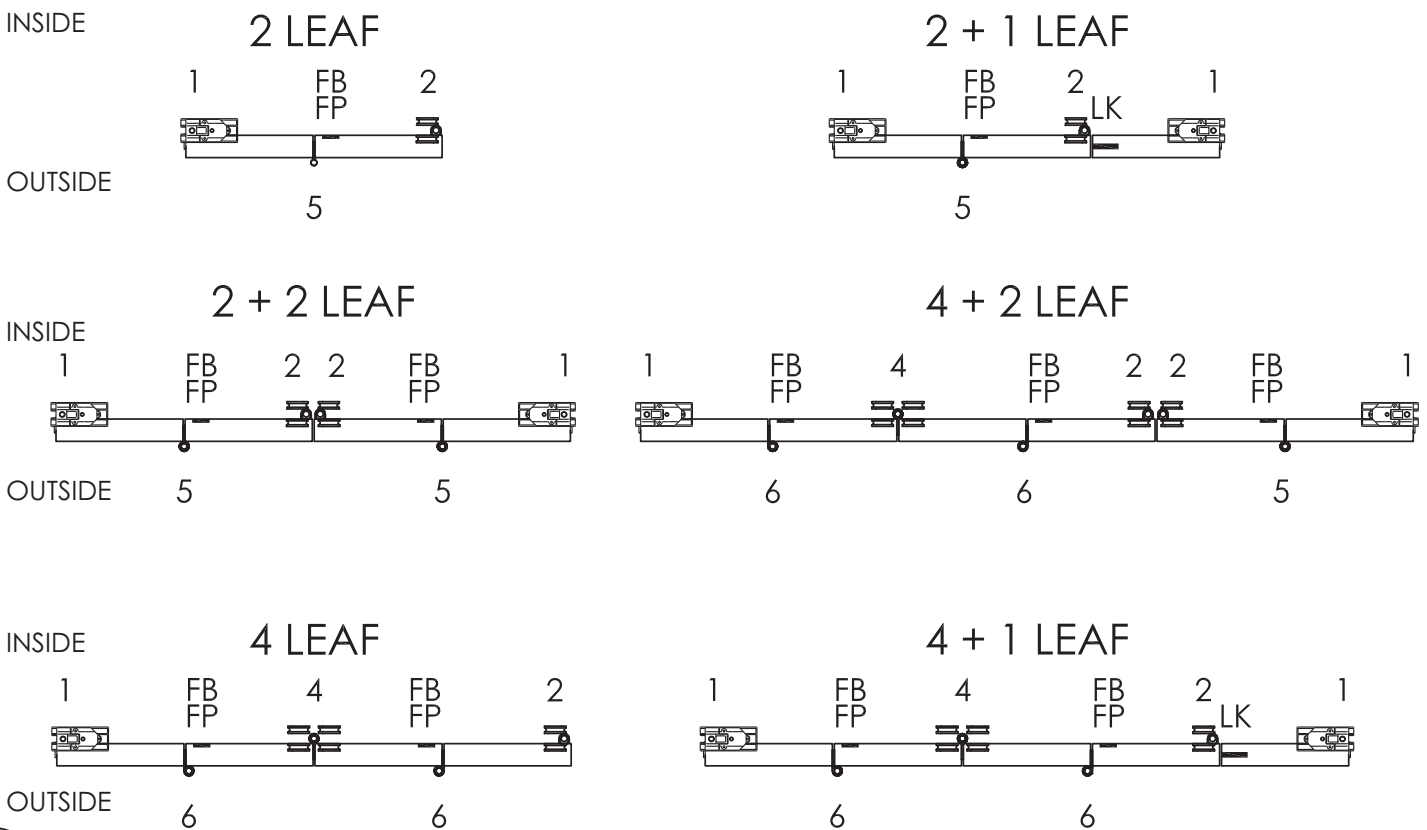

Opening Preparation outward opening system shown, dimensions shown in mm[inches]

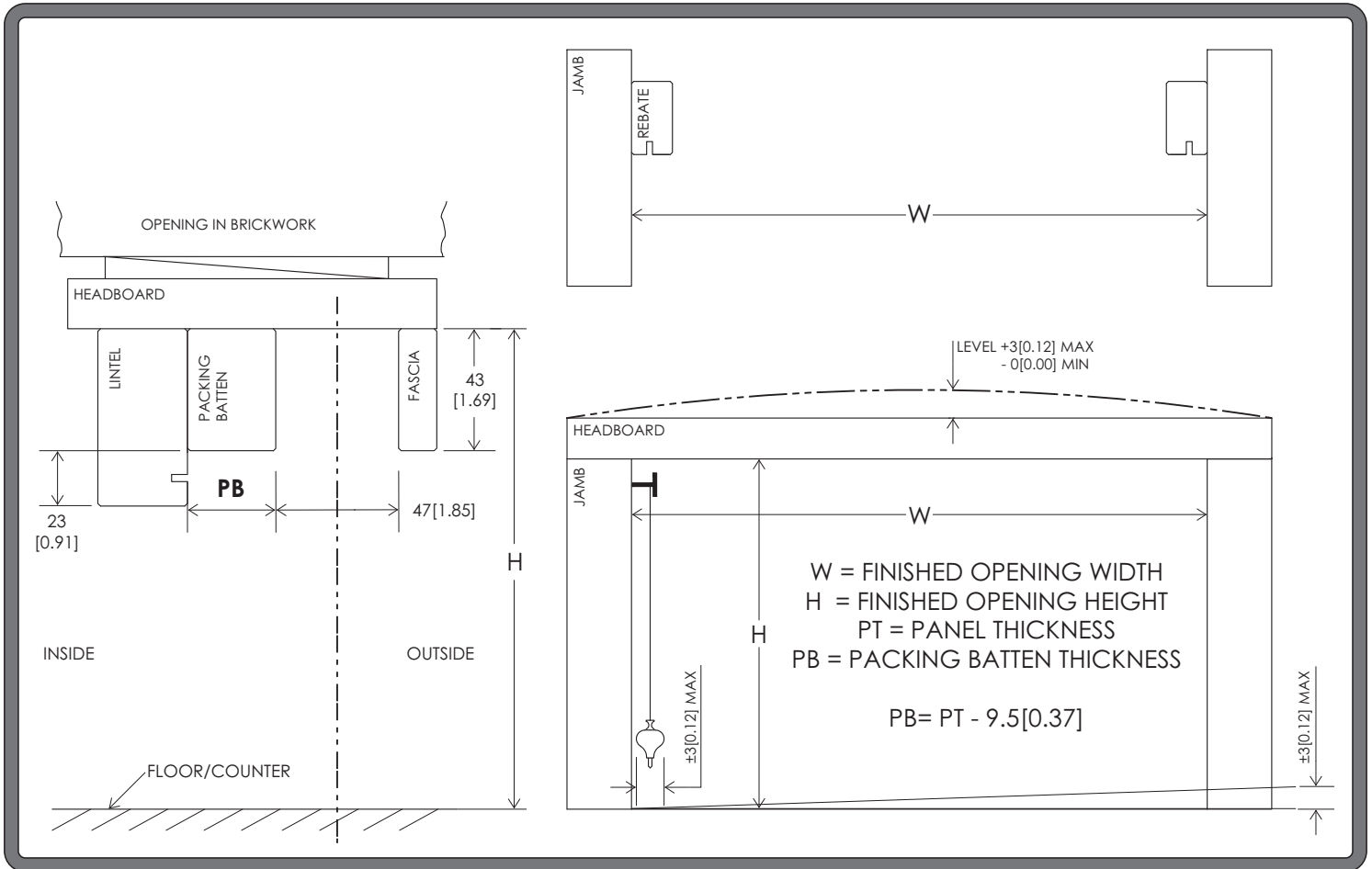

Track Preparation track and channel cut to length 'W' (finished opening width)

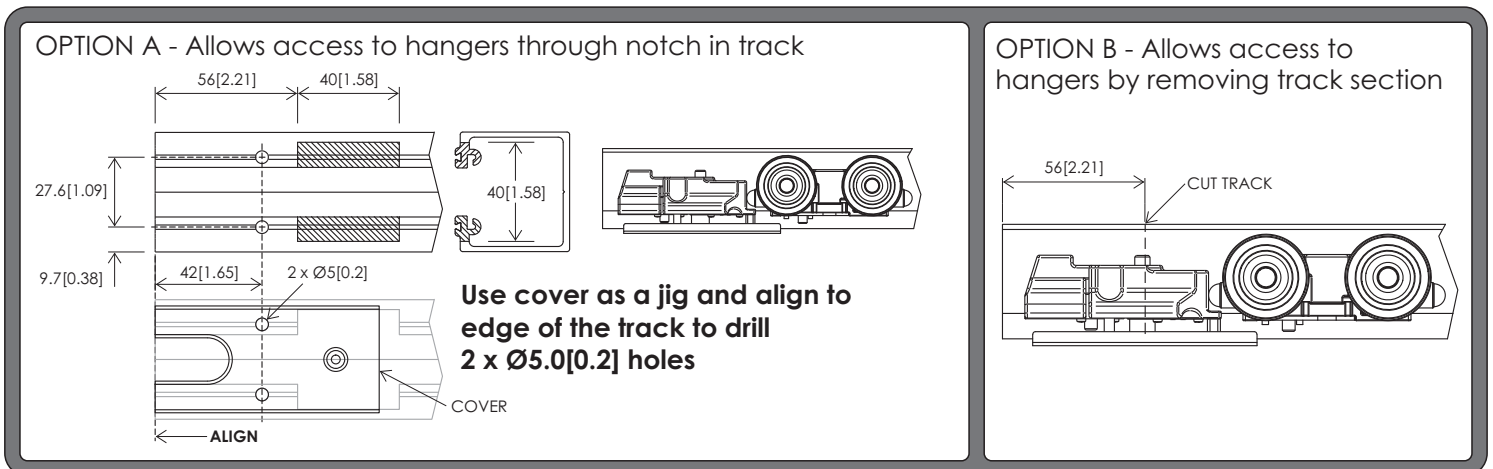

Install Track & Channel

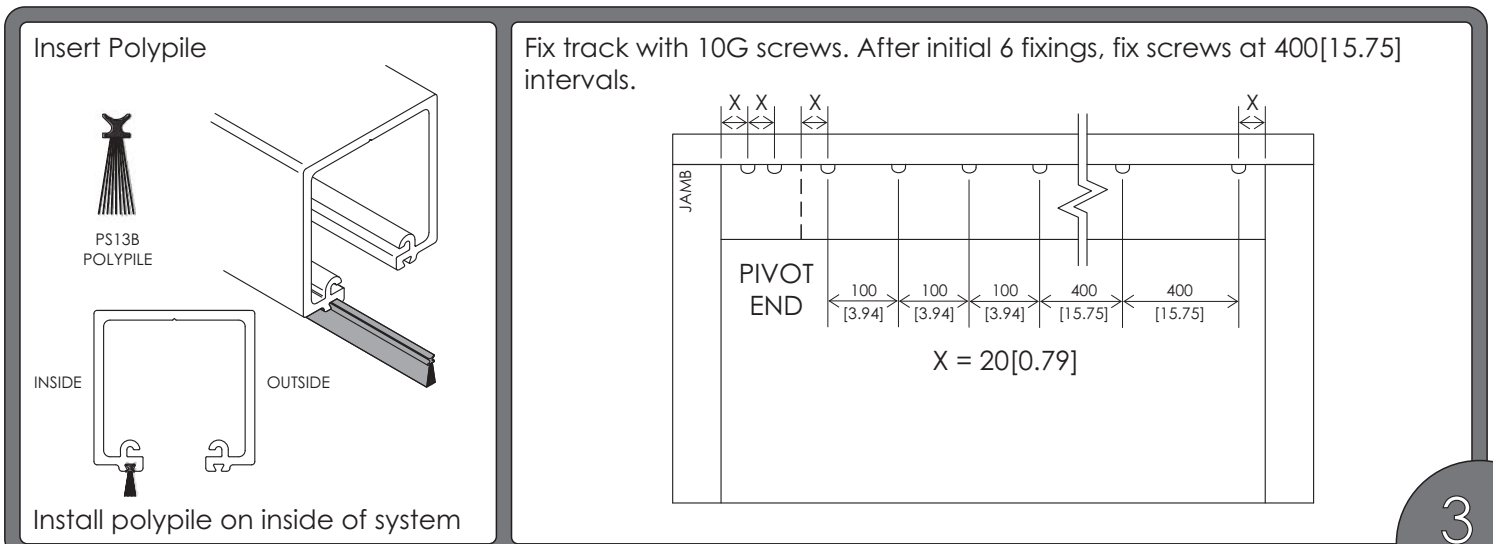

Panel Size Calculation

Brio Weatherfold 4s allows for equal size panels

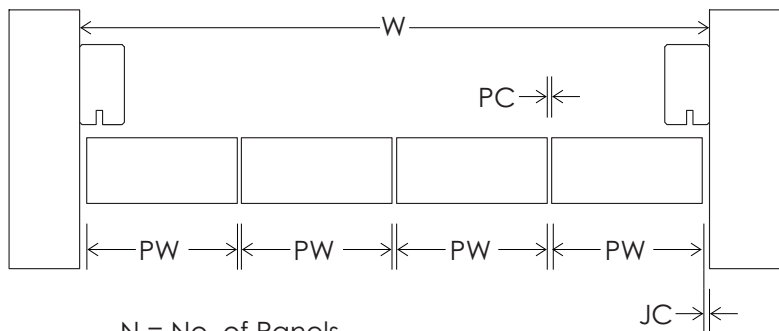

N = No. of Panels
 PW = Panel Width
 JC = Jamb Clearance = 6[0.24]
 PC = Panel Clearance = 4[0.16]

$$PW = \frac{W - [PC(N-1) + 2(JC)]}{N}$$

JC based on panels 600[23.62] wide and 40[1.57] thick.

PH = Panel Height

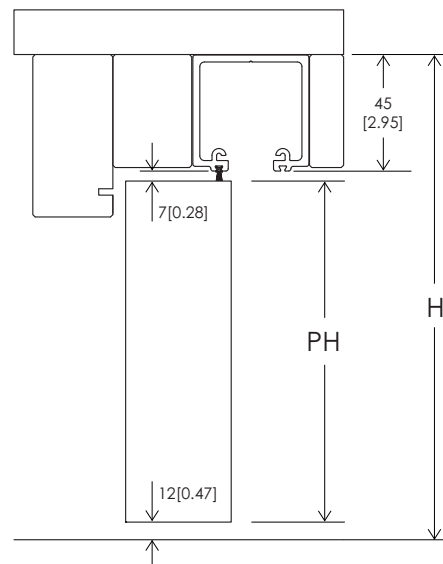

$$PH = H - 64[2.52]$$

Seal Preparation For exterior systems. Left, outward opening system shown

Frame - AQ21 perimeter seals to butt against each other in all corners

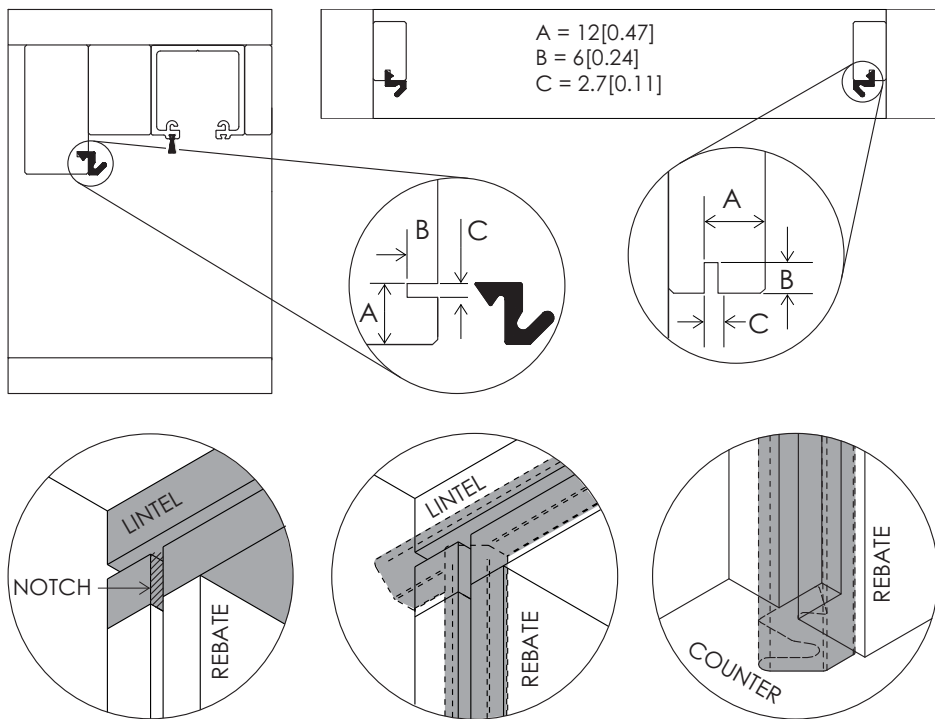

Lintel to be notched as shown.

Meeting Door Selection Panel thickness 35[1.38] minimum

2 Meeting square doors

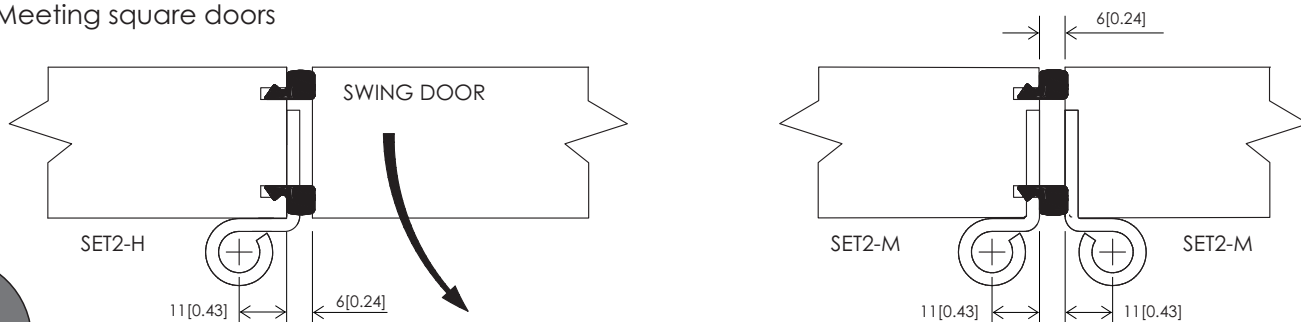

Hinge Installation

pilot hole of Ø2.5mm[0.12"] recommended. Panel thickness 35[1.38] minimum.

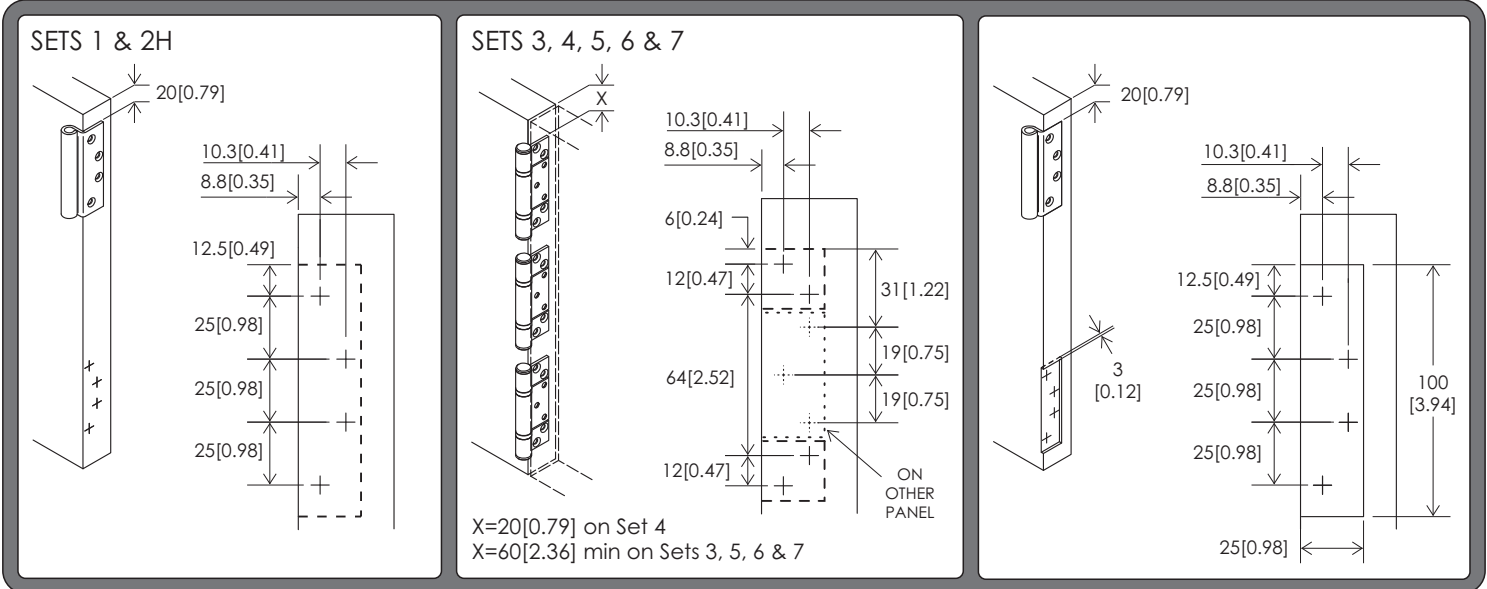

Flush bolt Position

see page 2 for flush bolt location for all configurations, router available

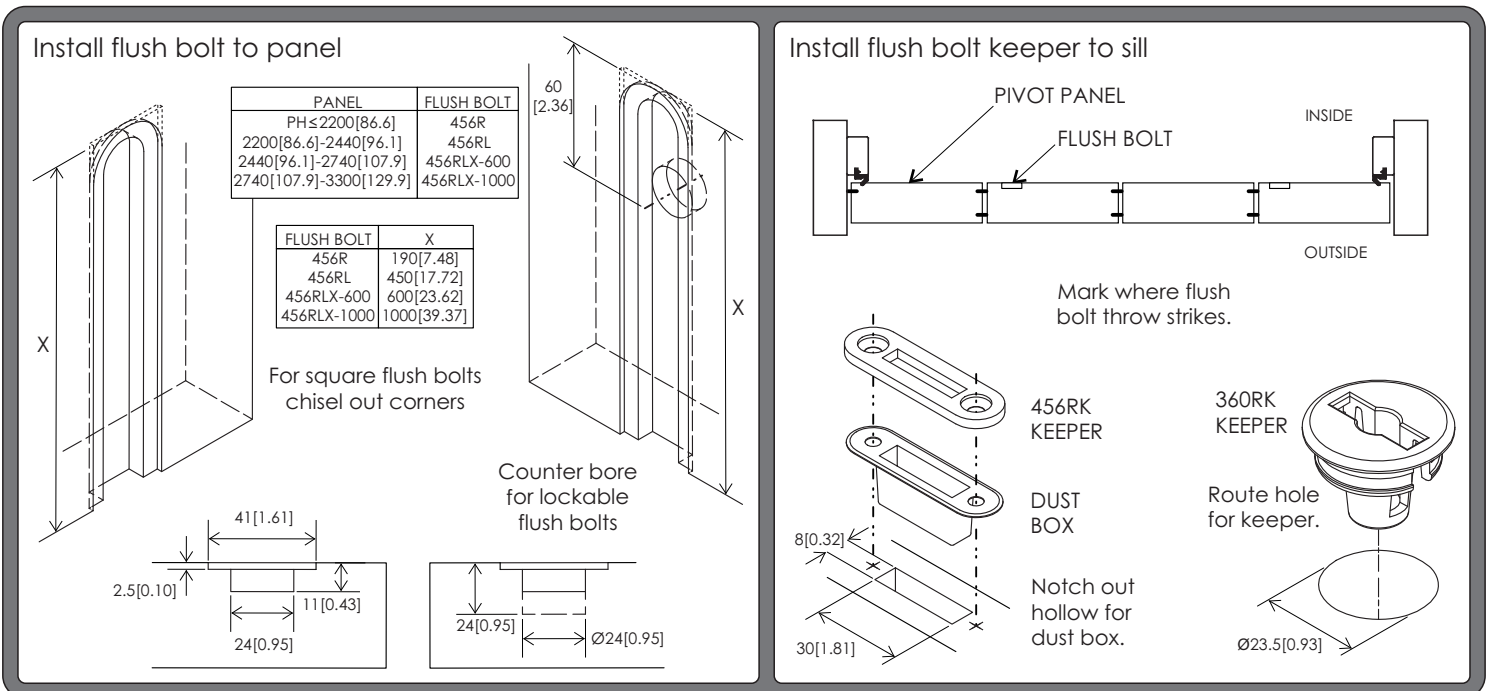

Installation of Bottom Pivot

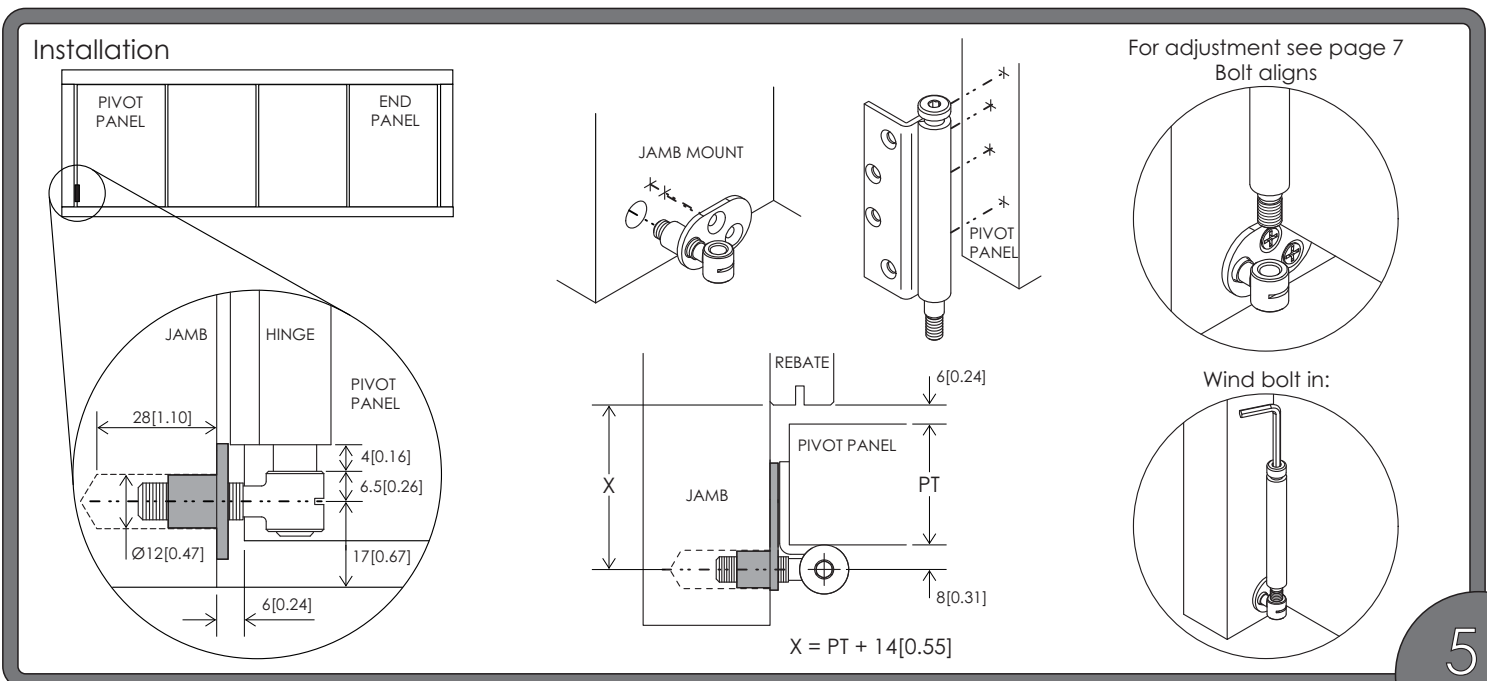

Determining System Orientation

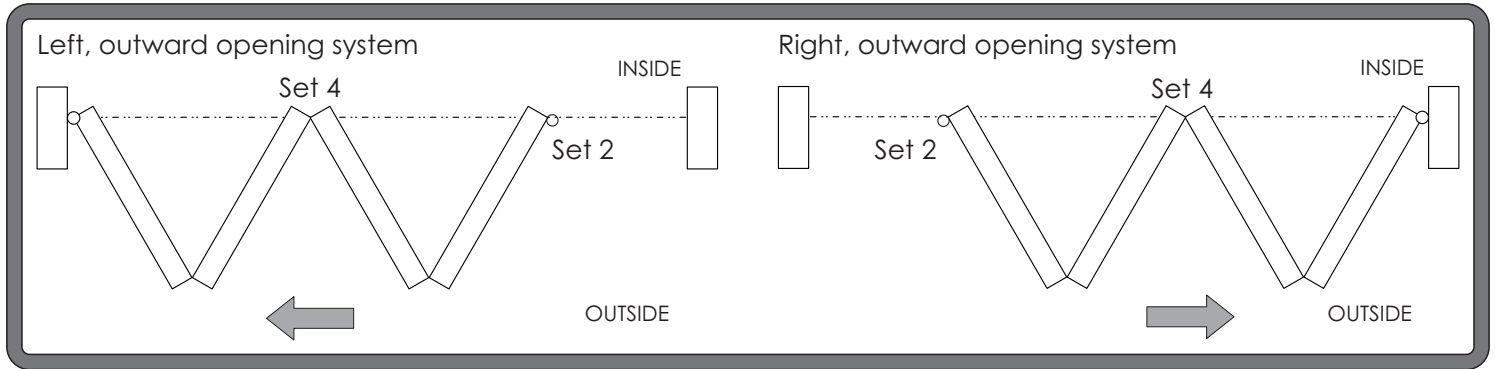

Attaching Hardware to Panels recommended before installation

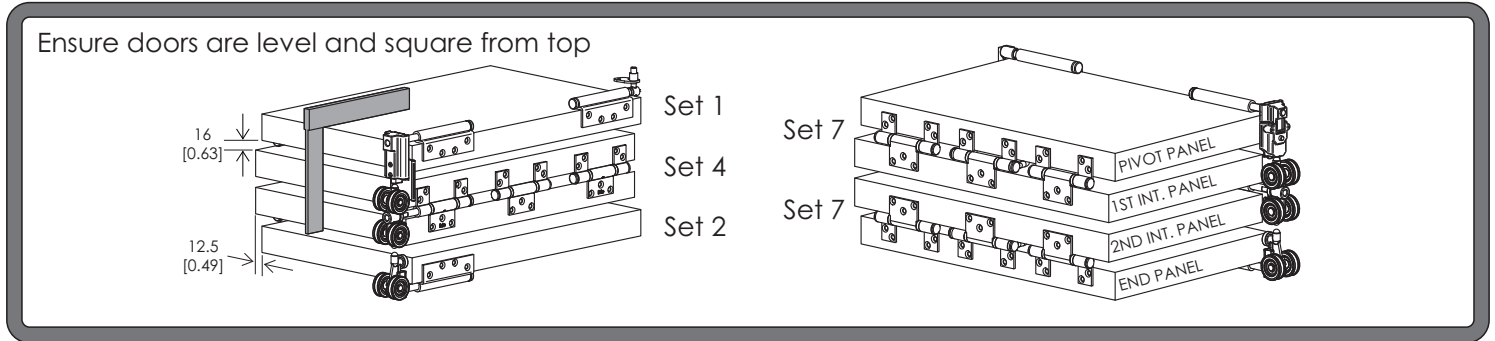

Installing Hardware and Hanging Panels clean down inside of track and channel

Insert rollers through access notch in correct order

JAMB

Viewed from the outside

Fix top pivot into position with machine screws supplied

JAMB

MACHINE SCREWS

Loosen locking screw and adjust top pivot so that hinge is touching the jamb. Lock off when in position.

PANEL

JAMB

HINGE TOUCHING JAMB

ADJUST

PIVOT BODY

Bring pivot panel to pivot set

TRACK

Hinge set 7 attached to panel

Bring 1st int. panel to pivot panel

Lower hinges of int. set attached

Fix int. hanger to int. panel

Bring 2nd int. panel to the int. hanger with hinge set 7

Bring end panel to hinge set 7

Fix end panel to end hanger

Close all panels

Adjustment

hinge pin locking mechanism applied to all hangers and top pivot

Adjust all hangers and top pivot until panels are parallel with 7mm gap between the track

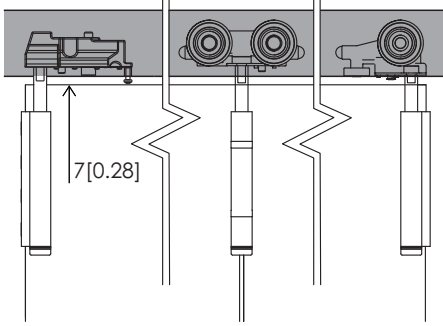

To adjust height, depress button and wind bolt. Bolt locks off automatically on flats.

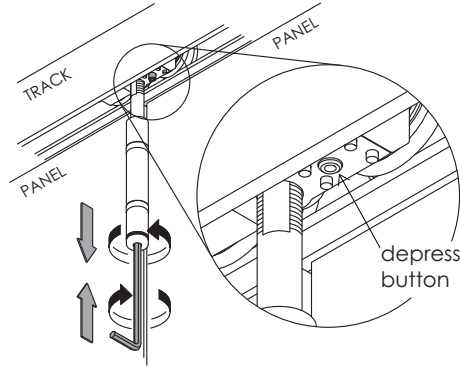

Remove from bolt from jamb pivot bolt to adjust doors.

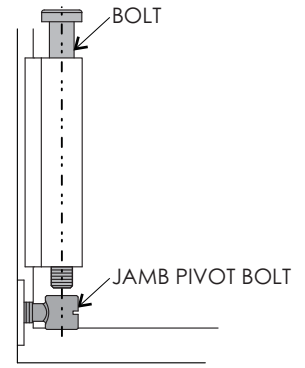

With the panels closed, loosen top pivot locking screw and adjust to centralise door panels. Then lock off top pivot.

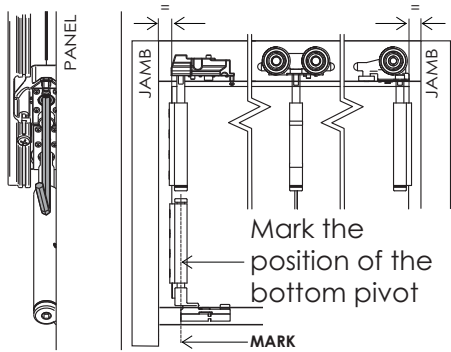

Wind jamb pivot bolt in or out until it aligns with hinge bolt on panel after top pivot is set.

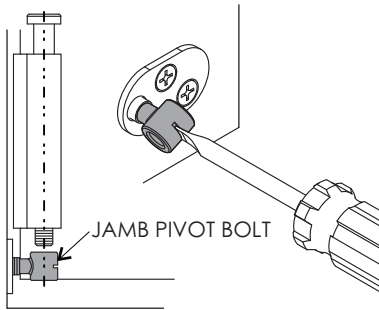

Close doors & fix cover into pivot to cover notch.

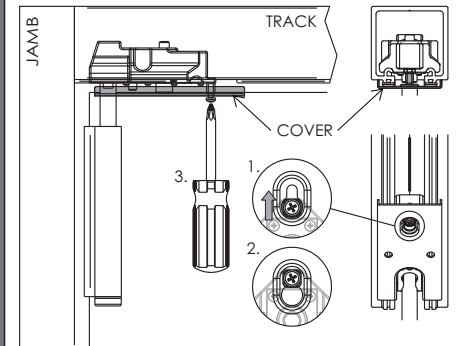

System Overview

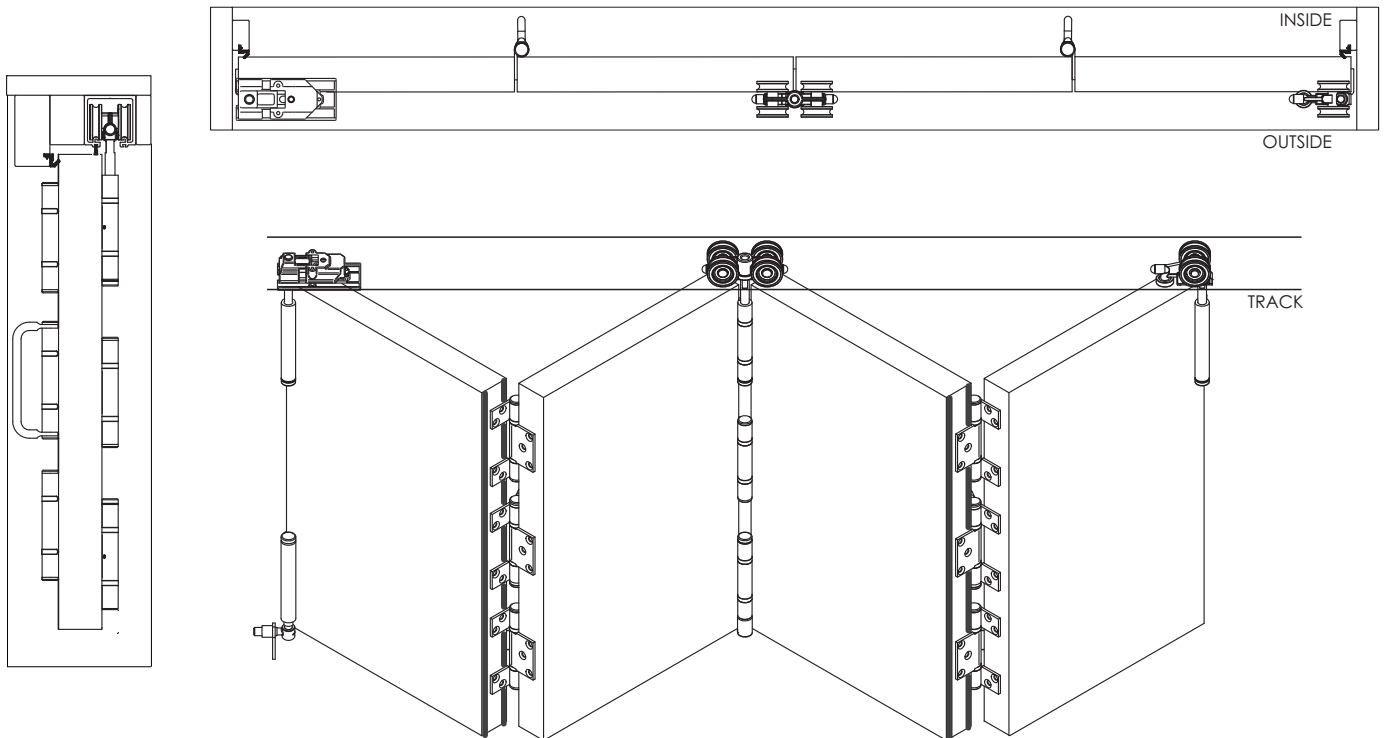

Care and Maintenance

Hardware is subject to deterioration from everyday use and from the environment that it is in. In particular, it is important that routine maintenance be carried out in harsh coastal or marine environments and industrial applications.

General

Inspect all fixing bolts for tightness every six months, including those securing brackets. Tighten if necessary. Routinely check for wear and if excessively worn, the part should be replaced.

To help prevent surface corrosion, Brio® recommends washing regularly; even stainless steel finishes in coastal environments may show signs of surface corrosion if not washed regularly. Sheltered areas that are not rain washed are particularly susceptible. Wash with soap or mild detergent and warm water followed by rinsing with clean cold water and wipe dry.

As a guide, if a window or door requires washing then wash the hardware, however Brio® recommend for marine and industrial environments washing a minimum of every 3 months and 6 months for general environments. In coastal or marine environments Brio® recommends applying a light application of corrosion preventative such as CRC Marine 66 or Inox® for Marine, to all surfaces and using a dry cloth to remove excess. When using lubricant or corrosion protection compounds, be careful to avoid the adjacent surfaces and always follow the manufacturer's instructions.

Track

Keep track free from obstruction and excessive dirt or water. Visible surfaces should be cleaned using a damp cloth and mild detergent, then wiped dry.

Where fitting to the outside of the building, it is recommended that the appropriate track is specified.

Hangers & Pivots

All hangers are fitted with lubricated ball-bearings or plain bearings, requiring no greasing. If doors 'settle' and door clearance is reduced causing friction, raise the door by the hanger adjustment nuts.

Wash as per the above recommendation and apply a light application of corrosion preventative to all surfaces, using a dry cloth to remove excess.

Guides

Guide roller and guide channel must be kept clear and free of obstructions.

Wash as per the above recommendation and apply a light application of corrosion preventative to all surfaces, using a dry cloth to remove excess.

Rollers

All bottom rails should be free from obstruction and excessive dirt or water. Visible surfaces should be cleaned using a damp cloth and mild detergent, then wiped dry. All rollers are fitted with sealed precision bearings requiring no maintenance.

Hinges

Visible surfaces should be cleaned using a damp cloth and mild detergent, then wiped dry. Apply a light application of corrosion preventative to all surfaces, using a dry cloth to remove excess. Repeat at intervals no greater than 3 months.

Flush Bolts

Visible surfaces should be cleaned using a damp cloth and mild detergent, then wiped dry. Apply a light application of lubricant to internal mechanisms and bolt using a suitable nozzle-spray.