

This Guide to Quantities is only applicable to Data Sheets D70.

Specifications and Quantities

The specifications below and overleaf detail the maximum and minimum capacities for the track systems recommended. Panels are hinged together to form either one or two units of up to six panels each, with each unit pivoted to one side of the opening. Openings can be covered by units of four or six 'floating' panels which are not hinged to the opening. Floating systems must include a guide.

If the panel weight is unknown, the weight can be calculated using the chart in Section 'A'. Having calculated the weight, use the information below to select the appropriate track system and quantities for the unit or units required to cover the opening width.

Specification for Individual Panels

Track System	Pivofold 35
Refer to Data Sheet	D70
Max Panel Height	2400mm
Max Panel Weight	35kg
Max Panel Width	900mm
Min Panel Thickness	35mm or 38mm with Flush Bolts
Max Number of Panels	6 each direction

2 Panel Unit Pivoted to one side

	Quantities	Product Codes
Track	See data sheet D50C	100
Bracket (face fix)	See data sheet D50C	1SS/250
Pivot Set	1	35EP
Hanger	1	35ENP
Hinges	3	282SS
Guide (optional)	1	106SSMF
Channel (optional)	See data sheet D50C	96W
Flush Pulls	2	401
Flush Bolt	1	456

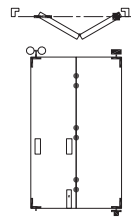

3 Panel Unit Pivoted to one side

	Quantities	Product Codes
Track	See data sheet D50C	100
Bracket (face fix)	See data sheet D50C	1SS/250
Pivot Set	1	35EP
Hanger	1	35ENP
Hinges	6	282SS
Guide	1	106SSMF
Channel	See data sheet D50C	96W
Flush Pulls	2	401
Flush Bolt	1	456

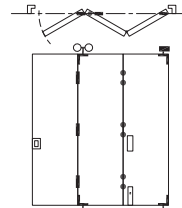

4 Panel Unit Pivoted to one side

	Quantities	Product Codes
Track	See data sheet D50C	100
Bracket (face fix)	See data sheet D50C	1SS/250
Pivot Set	1	35EP
Hanger	2	35ENP
Hinges	9	282SS
Guides	2	106SSMF
Channel	See data sheet D50C	96W
Flush Pulls	3	401
Flush Bolt	2	456

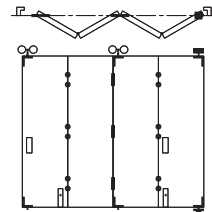

4 Panel 'Floating' Unit

	Quantities	Product Codes
Track	See data sheet D50C	100
Bracket (face fix)	See data sheet D50C	1SS/250
Hanger	3	35ENP
Hinges	9	282SS
Guides	2	106SSMF
Channel	See data sheet D50C	96W
Flush Pulls	3	401
Flush Bolt	2	456

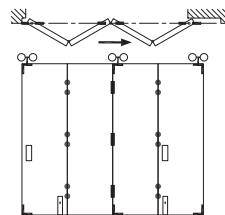

5 Panel Unit Pivoted to one side

Track	See data sheet D50C
Bracket (face fix)	See data sheet D50C
Pivot Set	1
Hanger	2
Hinges	12
Guide	2
Channel	See data sheet D50C
Flush Pulls	3
Flush Bolt	2

Product Codes

100
1SS/250
35EP
35ENP
282SS
106SSMF
96W
401
456

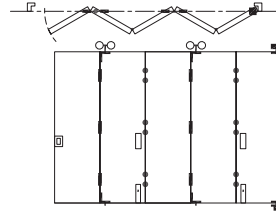

6 Panel Unit Pivoted to one side

Track	See data sheet D50C
Bracket (face fix)	See data sheet D50C
Pivot Set	1
Hanger	3
Hinges	15
Guides	3
Channel	See data sheet D50C
Flush Pulls	4
Flush Bolts	3

Product Codes

100
1SS/250
35EP
35ENP
282SS
106SSMF
96W
401
456

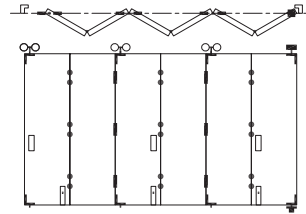

6 Panel 'Floating' Unit

Track	See data sheet D50C
Bracket (face fix)	See data sheet D50C
Hangers	4
Hinges	15
Guide	3
Channel	See data sheet D50C
Flush Pulls	4
Flush Bolt	3

Product Codes

100
1SS/250
35ENP
282SS
106SSMF
96W
401
456

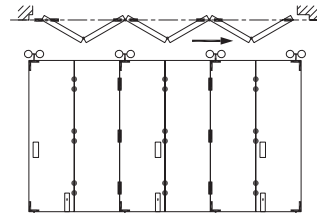

2 Additional Panels

Hanger	1
Hinges	6
Guide	1
Flush Pull	1
Flush Bolt	1

Product Codes

35ENP
282SS
106SSMF
401
456

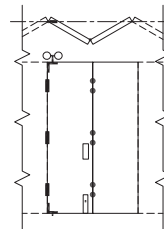

Track, Bracket and Channel Quantities

From the table below, choose the quantities of applicable track, bracket and channel.

Track and Channel

Choose sufficient track and channel to cover the overall opening width. If a 'floating' unit is required to slide clear of the opening, then sufficient track and channel is required to cover the widths of the stacking bay and the opening.

Bracket Spacing (Face Fix)

Place a bracket at 50mm in from both ends of the track, on each track used. Install next bracket 100mm in from the first bracket on the end which panels will pivot from. If using 6 panels, install another bracket 100mm in from the second bracket. Then install a bracket at approximately 400mm intervals.

Opening Width	Track Length	Bracket Quantity	Channel lengths
2000 (1 unit of 3 panels)	1 x 2000	7	1 x 2000
3000 (1 unit of 4 panels)	1 x 3000	9	1 x 3000
4000 (1 unit of 6 panels)	1 x 4000	12	1 x 4000
5000 (1 unit of 6 panels)	1 x 5000	15	1 x 5000
6000 (1 unit of 6 panels)	1 x 6000	17	1 x 6000
7000 (2 units of 4 panels)	1 x 3000 } 1 x 4000 }	21	1 x 3000 } 1 x 4000 }

If using two units which pivot from both sides of the opening, repeat the 100mm fixing point on both ends of the track

If using floating panels, increase fixing points in location where panels will be stacked in the open position.

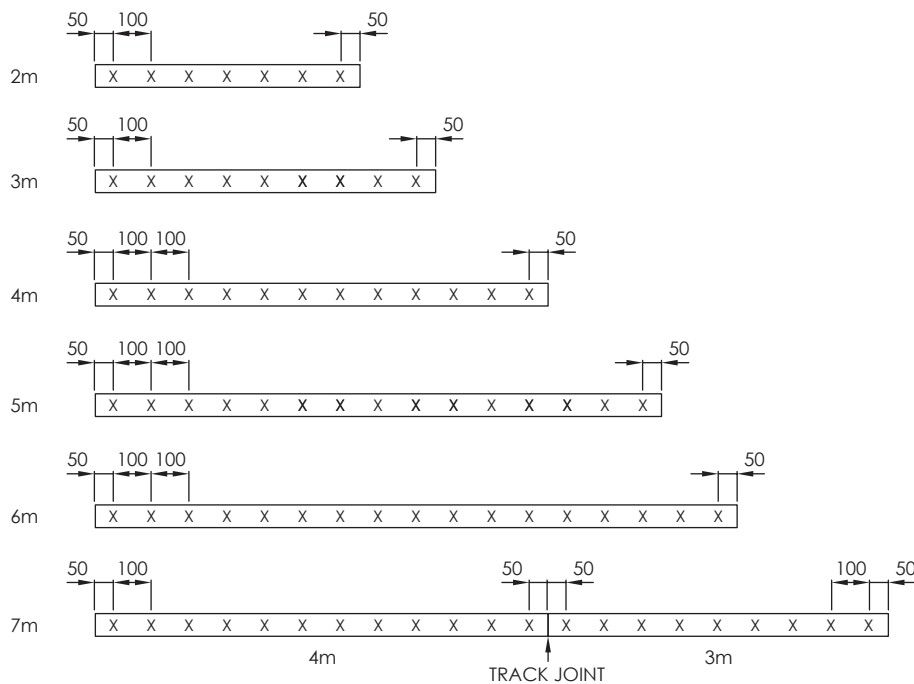

X = BRACKET POSITION APPROX. 400mm SPACINGS UNLESS OTHERWISE SPECIFIED



Application

Suitable for residential and light commercial folding partitions, using equal sized panels.

Panels can fold to one or both sides of the opening.

To cover any width opening, any number of folding units can be used.

Panel Specification

Track System:	Pivoffold 35
For Individual Panels:	
Max Panel Height	2400mm
Max Panel Weight	35kg
Max Panel Width	900mm
Min Panel Thickness	35mm or 38mm with Flush Bolts

Units of up to six panels can be pivoted to each side of the opening. Units with an odd number of panels provide an access panel.

A guide system across the floor must be used on units of three panels or more. Floating units consist of four or six panels.

Panels should be constructed to provide secure fitting for the pivot sets, hangers, hinges and guides.

Standard Packs

Pack No.	Hardware for	Content
PF35-2PKNC	2 Panel (No Channel)	Pivot, hanger, door stop, three hinges, all timber screws and instructions.
PF35-2PK	2 Panel Pack	Pivot, hanger, door stop, guide, three hinges, all timber screws and instructions.
PF35-4PK	4 Panel Pack	Pivot, two hangers, door stop, two guides, nine hinges, all timber screws and instructions.
PF35-6PK	6 Panel Pack	Pivot, three hangers, door stop, three guides, fifteen hinges, all timber screws and instructions.
PF35-APK	Add on 2 panel pack	Hanger, guide, six hinges, all timber screws and instructions.

For any folding units select one basic pack and sufficient PF35-APK add-on fitting packs and a suitable length of 100 track (see below) to cover width of opening.

Hardware Specification

Track:	100
Material	Aluminium, Mill or Clear Anodised
Standard Lengths	2000mm, 3000mm, 4000mm and 6000mm

Bracket (Face Fix):	
Bracket 316 Stainless Steel	1SS/250
Brackets located close together at the pivot end of the track with other brackets at 400mm centres.	

Hanger:	35ENP
Hanger fitted with nylon tyre wheels on ball race bearings. Vertical adjustment is simple and positive.	

Pivot Set:	35EP
Top and bottom pivot sets	

Guide:	106SSMF
Stainless steel plate with precision bearing	

Hinge:	282SS
Stainless steel hinge for 19mm minimum panel thickness, 65mm tall, non-mortice	

Channels:	
Aluminium	96W
Finish	Clear Anodised
Standard Lengths	2000mm, 3000mm, 4000mm and 6000mm

Accessories:	
Flush Pull	401
Flush bolt	456

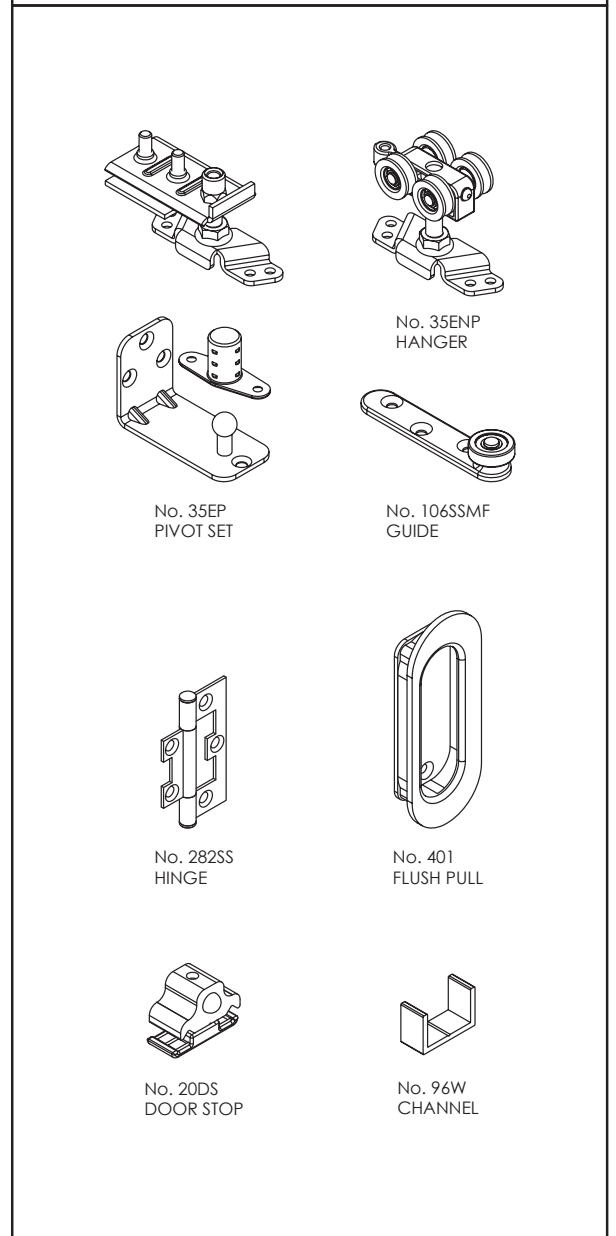

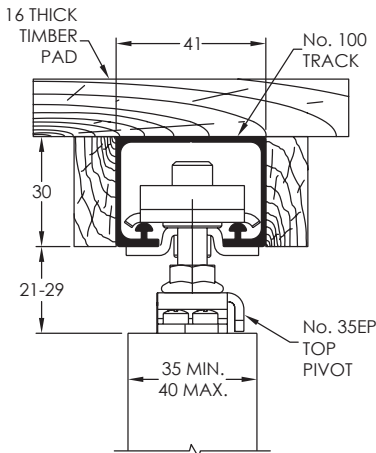

PANEL PREPARATION

No. 35ENP HANGER AND No. 35EP TOP PIVOT

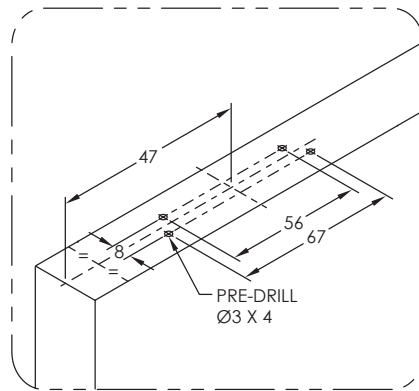

No. 35EP - BOTTOM PIVOT SOCKET

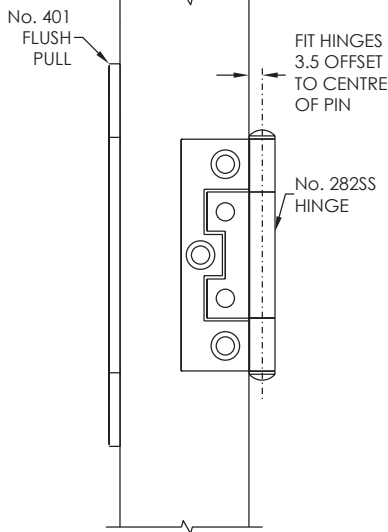
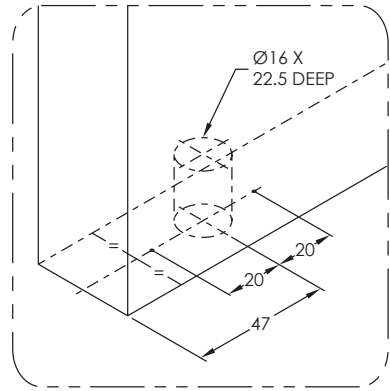

**2 OR 2+2 PANEL:
NO GUIDE AND CHANNEL**

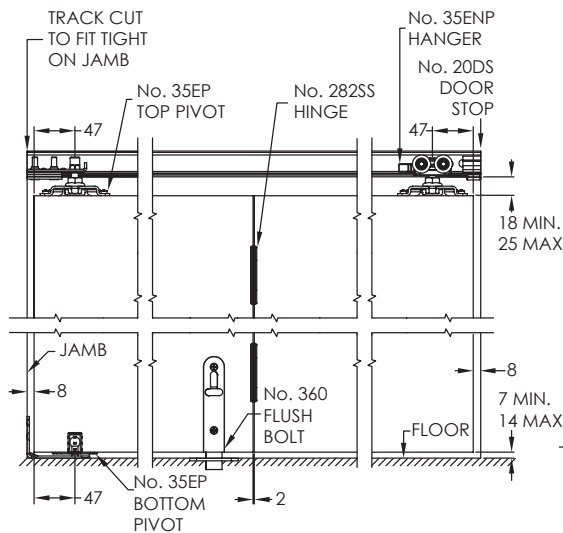

**4 - 6 PANEL
No. 106SSMF GUIDE WITH No. 96W CHANNEL
(IF USING FLUSH BOLTS - 38 MIN PANEL THICKNESS)**

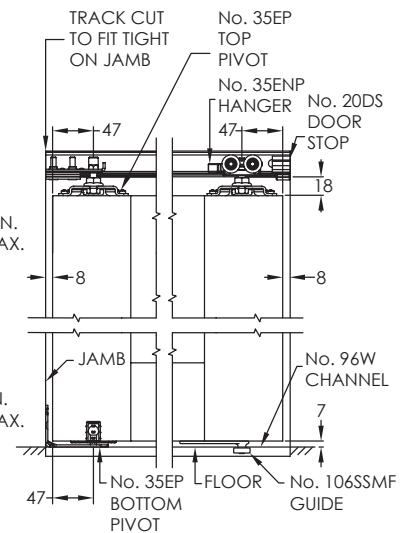

**2 OR 2+2 PANEL:
NO GUIDE AND CHANNEL**

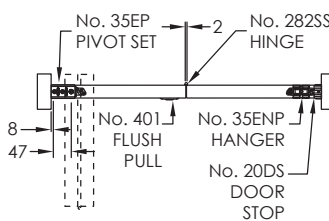

**4 PANEL
No. 106SSMF GUIDE WITH No. 96W CHANNEL
(IF USING FLUSH BOLTS - 38 MIN PANEL THICKNESS)**

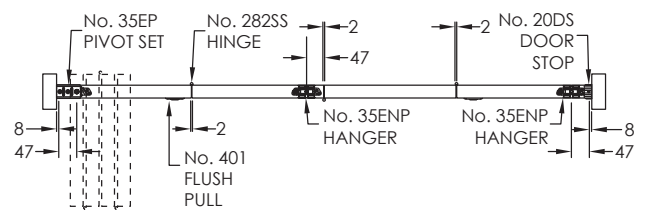

**6 PANEL
No. 106SSMF GUIDE WITH No. 96W CHANNEL
(IF USING FLUSH BOLTS - 38 MIN PANEL THICKNESS)**

