

Application

Widely used in commercial, industrial and agricultural applications.

To accommodate different building designs, panels can slide to one or both sides.

Where panels are fitted externally, a canopy is recommended.

Panel Specification

Track System:	Single Run 300	Single Run 800
For Individual Panels:		
Max Panel Height	3600mm	4200mm
Max Panel Weight	300kg	800kg
Panel Thickness	43-57mm	43-57mm

For ease of operation it is recommended that the panel width should not exceed 75% of panel height.

Timber panels for interior use can be of flush construction or glazed. Timber panels for industrial applications should be framed, ledged and braced. Metal panels should be constructed of box section, channel or angle framing, well braced and clad with flat or corrugated sheets.

Hardware Specification

Track:	800	800
Material	4mm Galvanised Steel	
Standard Lengths	2000mm, 3000mm, 4000mm & 6000mm	

Brackets:	6mm pressed steel painted grey primer	
Face fitted - open	1S/800	1S/800
Soffit fitted - open	2S/800	2S/800
Bracket End Clip	800EC	800EC

Hangers (2 per panel):		Steel Tyre
Timber Panel - plate fitting	57BN	57BS
Metal Panel - box frame	56BLN	56BLS
Metal Panel - plate fitting	57BN	57BS

Hanger supplied with timber screws, fixing plate and precision bearings. Vertical adjustment is simple and positive. Nylon tyre wheel hangers should not be used on installations involving temperatures exceeding 80°C.

Steel tyre hangers have solid steel wheels and are fitted with ball race bearings. All steel parts are zinc plated.

Guides:		
Plate Fix Stainless Steel	106RB/94	106RB/94

Channels:		
Aluminium	94A	94A
Brass	94B	94B
Aluminium Support & Polypropylene	94PPA	94PPA
Standard Lengths	2000mm, 3000mm, 4000mm and 6000mm	

Accessories:		
Flush Pulls	401D	401D
Flush Bolts	456	456
Track Stops	800DS	800DS

Flush bolts and flush pulls are available in (PVDB) PVD Brass, (SN) Satin Nickel & (PN) Polished Nickel

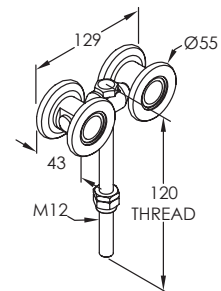
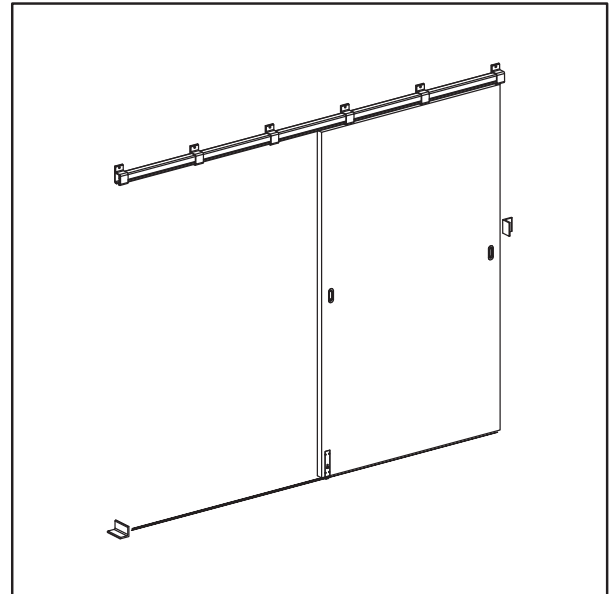

No. 56BLN
No. 56BLS
HANGER

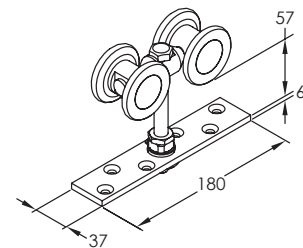

No. 57BN or
No. 57BS
HANGER

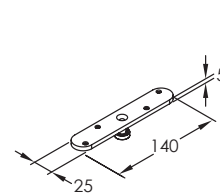

No. 106RB/94
GUIDE

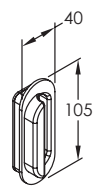

No. 401D
FLUSH PULL

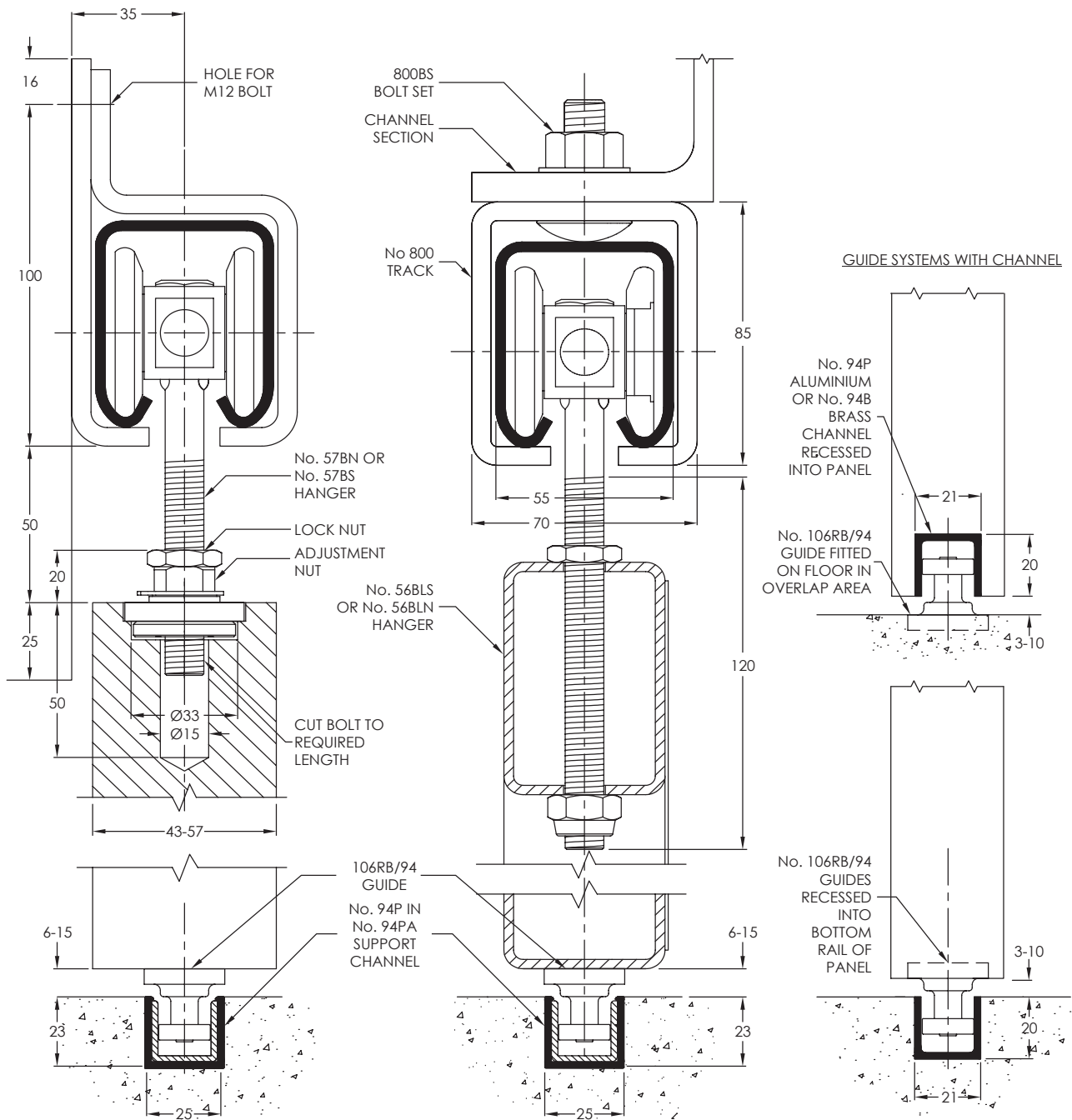

HARDWARE PLACEMENT
FRONT VIEW (PANEL SLIDING INSIDE)

BRACKET PLACEMENT
32.5mm TO CENTRE OF FIRST BRACKET FROM EACH END, THEN A BRACKET APPROXIMATELY EVERY 400mm CENTRES.

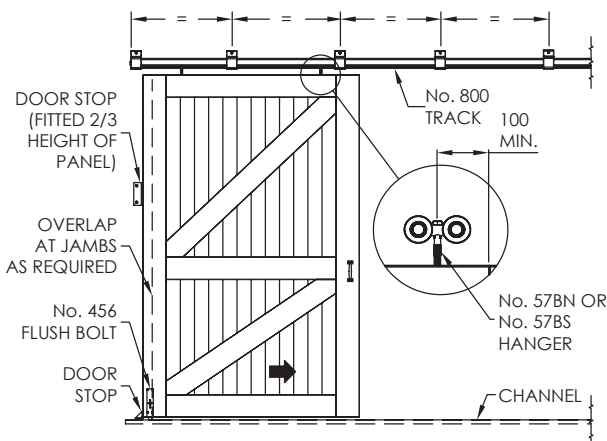

STANDARD TRACK LENGTH	2000	3000	4000	6000
No. OF BRACKETS	6	9	11	16

