

Application

Suitable for interior top hung sliding panels.

Ideal for residential situations where smooth and silent operation is of major importance e.g. bedrooms and nurseries.

Suitable for a single panel or for two panels on a bi-parting installation - panel width limits apply.

The track can be either face or soffit fitted.

Panel Specification

Track System:	Twinwheel 45
For Individual Panels:	
Max Panel Weight	45kg
Max Panel Width	1520mm
Min Panel Width	620mm
Min Panel Thickness	25mm

Suitable for use with timber framed panels of flush, panelled or glazed construction. Provision must be made for fitting the hanger top plates securely, since the hanger strikes the door stops.

Standard Sets

Sets comprise of top track, hanger assembly, door stops, guide, all timber screws and installation instructions.

Set No.	Suitable for	Min and Max panel width	Track Length
TW45-16/1	Single panel	620mm to 920mm	1630mm
TW45-22/1	Single panel	920mm to 1220mm	2230mm
TW45-28/1	Single panel	1220mm to 1520mm	2830mm
TW45-33/2	Bi-parting panels	620mm to 870mm	3320mm

Hardware Specification

Track:	171
Material	Aluminium, Mill

Hanger assembly:	172
Material	Aluminium, Mill

The track and hanger assembly on each standard sets, are specifically designed for the minimum and maximum travel of the panel and are not available in other sizes.

The track has a rounded trough for smooth operation and a 'hooded' top to prevent the hanger assembly jumping off the track. The track can be sidewall or soffit fitted. The aluminium extruded hanger assembly is in one piece for ease of fitting and correct alignment of wheels. The nylon wheels, with integrated bronze axles, provide a friction reduced differential action.

Top Plate:	172P
-------------------	------

The steel top plate, complete with adjusting bolt, washers and nut, allows ample vertical and lateral adjustment. Components are zinc plated.

Door Stop:	173
-------------------	-----

The zinc plated steel door stop includes a rubber buffer. The stop is fitted into the track and is secured in place with a screw beneath the track.

Guide:	55G
---------------	-----

Guide in white nylon, comes in two parts that fit on both sides of the panel. The guide is floor mounted.

Accessories:	
Alternative Guide	102WA

Guide in zinc plated steel, has lateral adjustment. Fits on the wall or architrave, in the overlap area, and slides through a 20mm deep by 5mm wide sawcut in the bottom rail of the panel. Floor left free of hardware.

Alternative Guide	103WA
-------------------	-------

Guide in white nylon, fits on the wall or architrave, in the overlap area, no need to groove the panel, since the guide supports the panel faces. The guide is adjustable for panels from 35mm to 45mm thick. Floor left free of hardware.

Alternative Guide	101N
-------------------	------

The nylon guide is designed to slide through a 20mm deep by 5mm wide sawcut in the bottom rail of the panel. The guide is fitted on the floor at the edge of the opening in the overlap area. The guide has lateral adjustment.

Pelmet	170
--------	-----

Pelmet in pearl white on aluminium. Hooks onto track, no screws required. Supplied with End Caps. Available in 1800mm and 3050mm lengths.

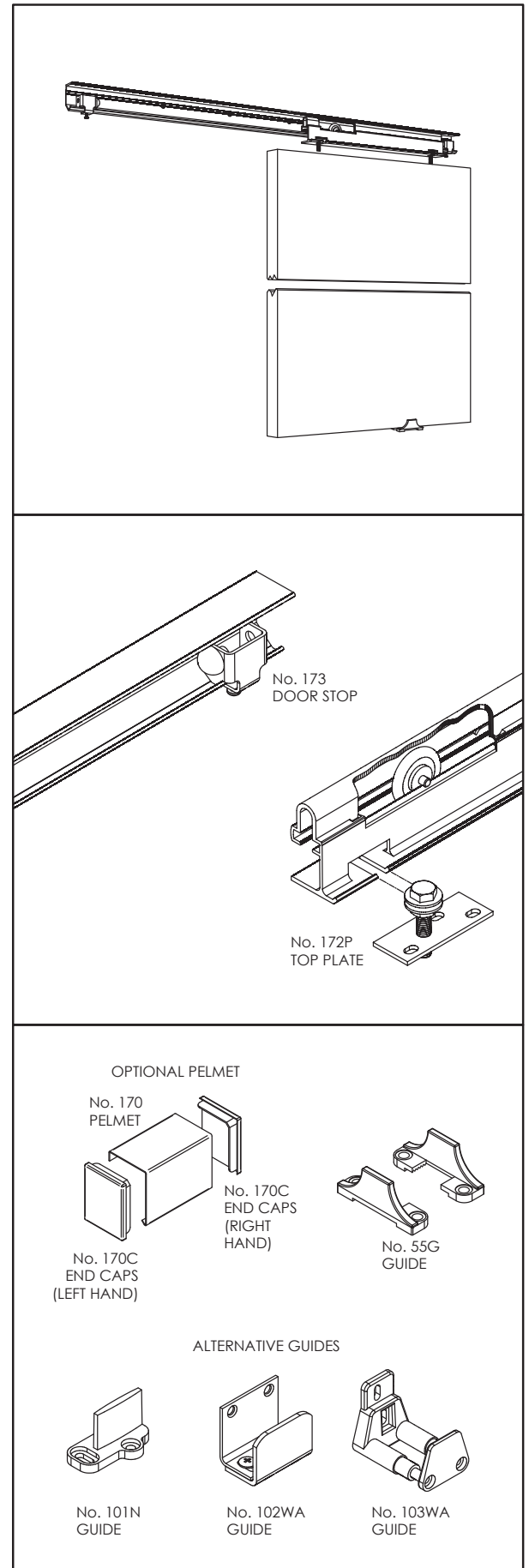

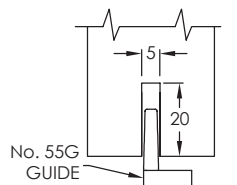
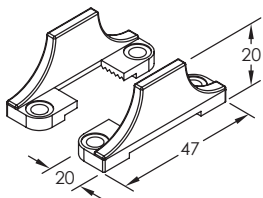
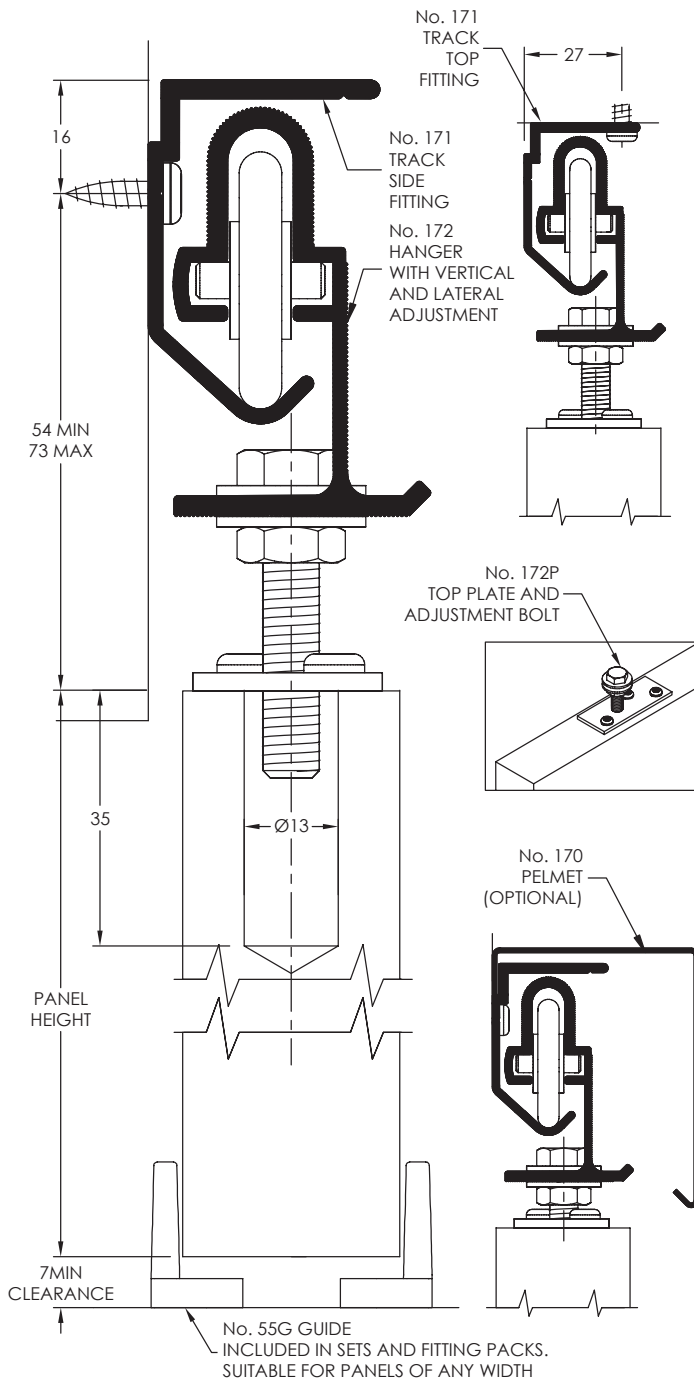

ALTERNATIVE GUIDES

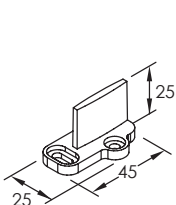

No. 101N GUIDE

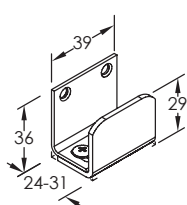

No. 102WA GUIDE

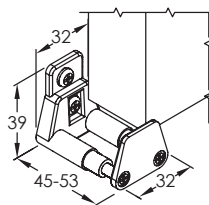

No. 103WA GUIDE

INSTALLATION INSTRUCTIONS

1 Fit Hanger to Panel

Drill two holes Ø13 x 35 deep, centrally in the top of the panel and the following centres:
 470 on panels 620-870 wide
 550 on panels 620-920 wide
 850 on panels 920-1220 wide
 1150 on panels 1220-1520 wide

Install top plates with the single screw hole towards the edge of the panel. To install top plates, use 32 long 10g screws in the centre of slotted holes with adjustment bolt in place

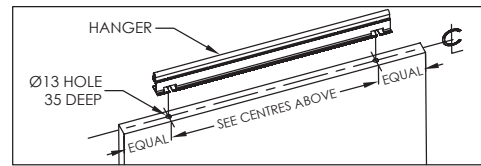

2 Fit Track to Wall

When side fitting the track refer to full size section top left and determine the position of the track. When top fitting refer to the half size drawing top middle. Install track securely and level with centre of track in line with the edge of opening. Wipe track clean of shavings.

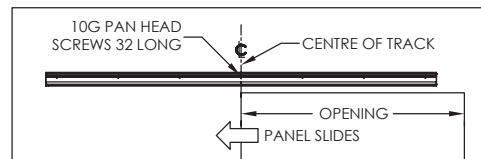

3 Lift Panel on to Track

Place the hanger in the track. Place bolt head and one washer in each slot in hanger. Hand tighten nuts and washers beneath hanger.

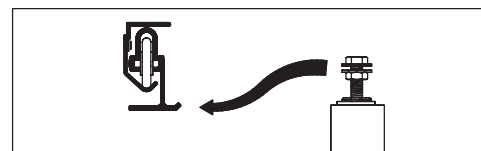

4 Adjust Panel

Adjust bolt to give required clearances. Ensure panel is plumb and square, finally tighten lock nuts. Check panel slides smoothly and silently.

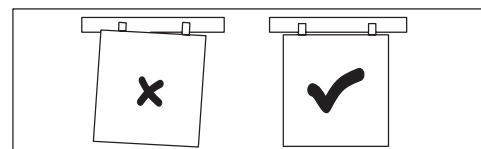

5 Fit Guide and Door Stop

Install the guide at the edge of the opening jamb. Screw through centre of slotted hole first, adjust guide so panel is vertical, the locate by screwing through round hole. Finally fit door stops in track. Position them so rubber buffer stops hanger in fully open and closed positions and tighten locking screws.

