

Application

For built-in panels sliding on a single track, i.e. wardrobes and cupboards in residential, heavy duty applications.

Easy height adjustment.

Silent operation - nylon wheeled bearing hangers and aluminium track.

Panel Specification

Track System:	Wardrobe Single 50
For Individual Panels:	
Max Panel Height	2400mm
Max Panel Width	900mm
Max Panel Weight	50kg
Panel Thickness	16-40mm

Lightly framed timber panels or panels made from medium density fibreboard (MDF) must have provision for hangers to be screwed securely to the back face of the panels

Standard Sets and Packs

Sets comprise of top track, hangers, door stop(s), sawcut guide(s), all timber screws and fitting instructions.

Wardrobe Single 50: Set No.	Panel width	Track Length	Hardware for
WS50-12/1	600mm	1200mm	1 panel
WS50-15/1	750mm	1500mm	1 panel
WS50-18/1	900mm	1800mm	1 panel

Pack No.
WS50-1PK Pack of fittings only, without track.

Hardware Specification

Track: 51
Material: Aluminium, Mill
Standard lengths: 1200mm, 1500mm, 1800mm, 2400mm, 3000mm and 3600mm

Hangers (2 per panel): 550, 551, 552
Nylon tyred ball race bearing with zinc plated plates face fitted to the back of the panel. Vertical adjustment 10mm.

Door Stop: 28N
Nylon safety door stop prevents fingers being jammed on bi-passing panels

Guide: 55G
Guide in white nylon, comes in two parts that fit on both sides of the panel. The guide is floor mounted.

Accessories:
Alternative Guide: 101N
The nylon guide is designed to slide through a 20mm deep by 5mm wide sawcut in the bottom rail of the panel. The guide is fitted on the floor at the edge of the opening in the overlap area. The guide has lateral adjustment.

Channel and Guide: 81 and 113N/81
113N/81 guides in white nylon. For heavy duty applications or where more than 3 panels are required per opening. 81 channel, aluminium, available in 1200mm, 1500mm, 1800mm, 2400mm, 3000mm and 3600mm lengths.

Pelmet: 170
Pelmet in pearl white on aluminium. Hooks onto track, no screws required. Supplied with End Caps. Available in 1800mm and 3050mm lengths.

End Caps: 170C
Made from high impact glass reinforced nylon polystyrene. The End Caps are a push-fit onto the pelmet.

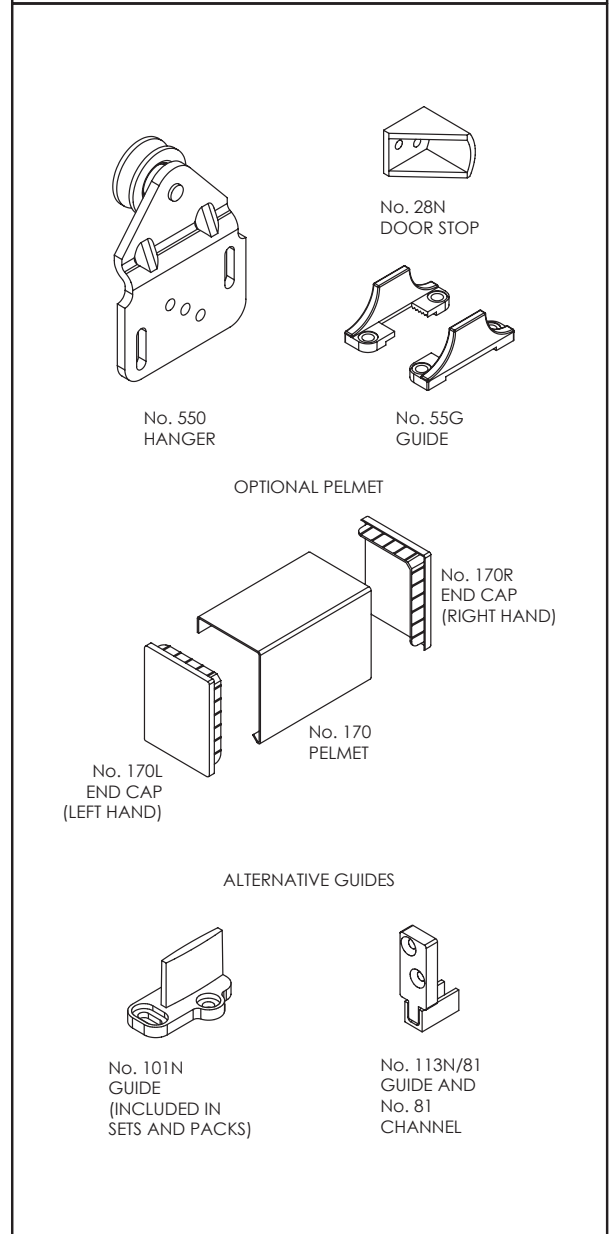
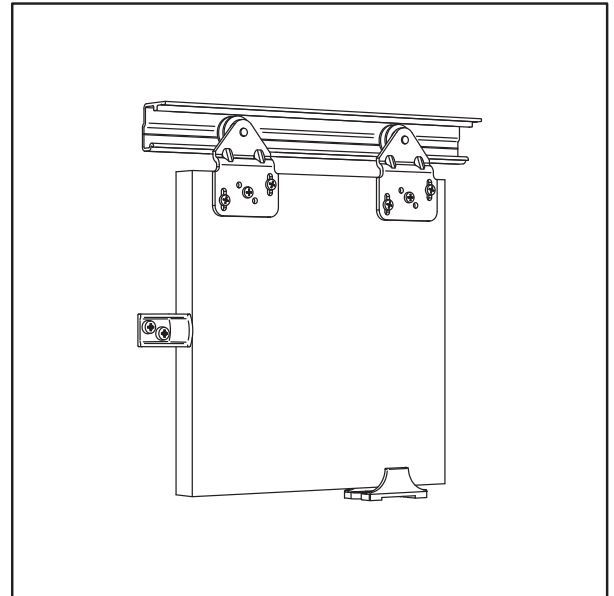

PANEL THICKNESS (PT)	22	25	29	32	35	38	40
DIMENSION 'A'	4	7	11	14	17	20	22
DIMENSION 'B' (PT + 9)	31	34	38	41	44	47	49

INSTALLATION INSTRUCTIONS

1 Prepare Panels

Door width = (Opening width / No. of panels) + 10mm (Overlap)
 For single panels + 10mm overlap each end.
 Panel height = Opening height less 53mm
 Track length = 2 x Opening width + Overlap

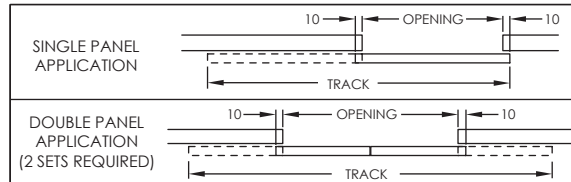

2 Fit Track

Panel thickness determines dimension 'A' - see table
 Face fix - fit track parallel to floor, packing batten 'A' mm thick
 Soffit fix - fit track 'A' mm from the outside edge of a level and flat lintel

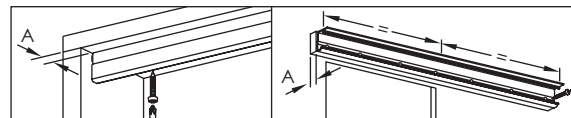

3 Fix Hardware to Panel

Align the plate shoulder level with the top edge of the panel. Screw 2 screws only in the centre of the slotted holes to give ±5mm vertical adjustment,



4 Fix Panel & Adjust

Hook panel onto track. Adjust hangers to obtain maximum floor clearance. When panels are hanging plumb and square fit a 3rd screw into one of the hanger locating holes

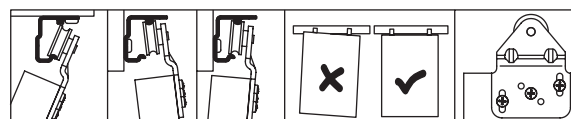

5 Fit Guide and Door Stop

With panel hanging plumb fix guide to overlapping area of opening. Screw holes facing inward under panel. Panels under 18mm thick, screw holes facing outward. Position door stop at 2/3 of panel height.

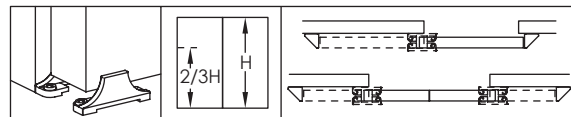

6 Optional Pelmet

The pelmet hooks onto the track and the end caps simply "push fit" into position. For face fix only. Notch packing batten for a closer fit to the panel.

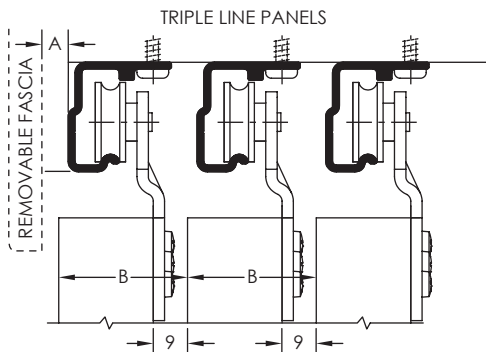
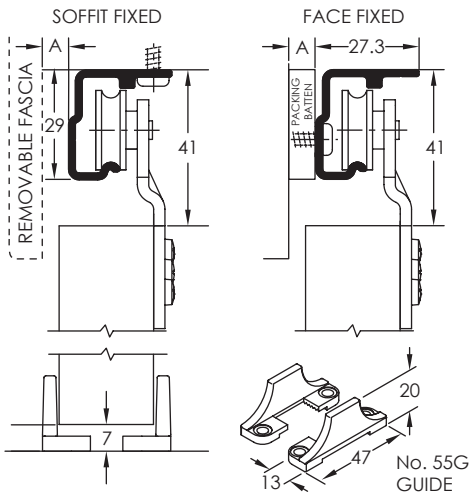
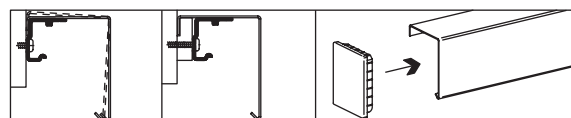

TYPICAL APPLICATION WITH OPTIONAL No. 170 PELMET No. 552 REVERSIBLE HANGER

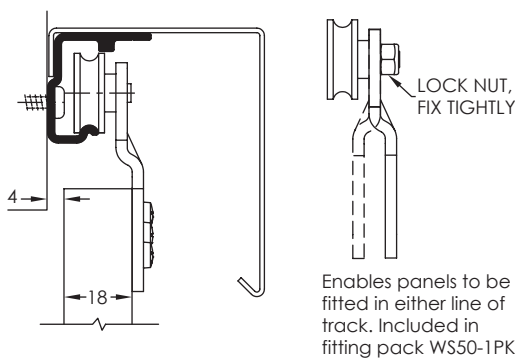

ALTERNATIVE GUIDES

