

Brio® Shutterfold 25, Screenfold 25 & Louvrefold 25 - Guide to Quantities

For Top Hung Exterior Folding Shutters, Screens and Louvred Panels

This Guide to Quantities is only applicable to Data Sheets E40, E50 & E60.

Specifications and Quantities

The specifications below and over leaf detail the maximum and minimum capacities for the track systems recommended. Panels are hinged together to form either one or two units of up to six panels each, with each unit pivoted to one side of the opening. Openings can be covered by units of four or six 'floating' panels which are not hinged to the opening.

If the panel weight is unknown, the weight can be calculated using the chart in Section 'A'. Having calculated the weight, use the information below to select the appropriate track system and quantities for the unit or units required to cover the opening width.

Specification for Individual Panels

Track System	Shutterfold 25	Screenfold 25	Louvrefold 25
Refer to Data Sheet	E40	E50	E60
Max Panel Height	2400mm	2400mm	2400mm
Max Panel Weight	25kg	25kg	25kg
Max Panel Width	900mm	900mm	900mm
Recommended Panel Thickness	35-50mm	19mm	35-50mm
Max Number of Panels	6 each direction	6 each direction	6 each direction

2 Panel Unit

	Quantities	Product Codes		
Track	1	100-A20	100-A20	100-A20
Pivot Set	1	21EPNC	21EPB	21EPB-A
Hinge	3	282SS		
Screen Hinges	2		135SS	135SS
Screen Hinges Handle	1		136SS	136SS
Hanger - End	1	21SS/EN	53SSEN	52EN-A
Guide	1		113RB/94	21ER-A
Flush Bolt - Bottom	1	360E	FFB85SS	FFB85SS
Flush Pull	1	401		
Channel	1		94A-A20	94A-A20

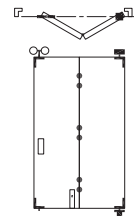

3 Panel Unit

	Quantities	Product Codes		
Track	1	100-A30	100-A30	100-A30
Pivot Set	1	21EP	21EPB	21EPB-A
Hinge	6	282SS		
Screen Hinges	5		135SS	135SS
Screen Hinge Handle	1		136SS	136SS
Hanger - Intermediate	1	21SS/EN	53SS/4EN	52EN/4-A
Guide	1		113RB/94	21ER-A
Flush Bolt - Bottom	1	360E	FFB85SS	FFB85SS
Flush Pull	2	401		
Channel	1	94PPA-A30	94A-A30	94A-A30

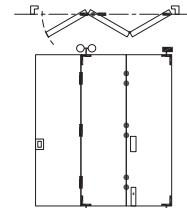

4 Panel Unit

	Quantities	Product Codes		
Track	1	100-A40	100-A40	100-A40
Pivot Set	1	21EP	21EPB	21EPB-A
Hinge	9	282SS		
Screen Hinges	7		135SS	135SS
Screen Hinge Handle	2		136SS	136SS
Hanger - Intermediate	1	21SS/EN	53SS/4EN	53EN/4-A
Hanger - End	1	21SS/EN	53SSEN	52EN-A
Guide	2	106E/94	113RB/94	21ER-A
Flush Bolt - Bottom	2	360E	FFB85SS	FFB85SS
Flush Pull	2	401		
Channel	1	94PPA-A40	94A-A40	94A-A40

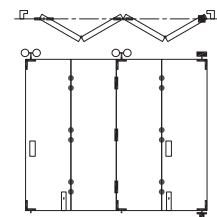

		Shutterfold 25	Screenfold 25	Louvre-fold 25
4 Panel Unit 'Floating'	Quantities	Product Codes		
Track	1	100-A40	100-A40	100-A40
Hinge	9	282SS		
Screen Hinges	7		135SS	135SS
Screen Hinge Handle	2		136SS	136SS
Hanger - Intermediate	1	21SS/EN	53SS/4EN	53EN/4-A
Hanger - End	2	21SS/EN	53SSEN	52EN-A
Guide	3	106E/94	113RB/94	21ER-A
Flush Bolt - Bottom	2	360E	FFB85SS	FFB85SS
Flush Pull	2	401		
Channel	1	94PPA-A40	94A-A40	94A-A40
2+2 Panel Unit	Quantities	Product Codes		
Track	1	100-A40	100-A40	100-A40
Pivot Set	2	21EP	21EPB	21EPB-A
Hinge	6	282SS		
Screen Hinges	4		135SS	135SS
Screen Hinge Handle	2		136SS	136SS
Hanger - End	2	21SS/EN	53SSEN	52EN-A
Guide	2	106E/94	113RB/94	21ER-A
Flush Bolt - Bottom	2	360E	FFB85SS	FFB85SS
Flush Pull	2	401		
Channel	1	94PPA-A40	94A-A40	94A-A40
5 Panel Unit	Quantities	Product Codes		
Track	1	100-A60	100-A60	100-A60
Pivot Set	1	21EP	21EPB	21EPB-A
Hinge	12	282SS		
Screen Hinges	10		135SS	135SS
Screen Hinge Handle	2		136SS	136SS
Hanger - Intermediate	2	21SS/EN	53SS/4EN	53EN/4-A
Guide	2	106E/94	113RB/94	21ER-A
Flush Bolt - Bottom	2	360E	FFB85SS	FFB85SS
Flush Pull	3	401		
Channel	1	94PPA-A60	94A-A60	94A-A60
6 Panel Unit	Quantities	Product Codes		
Track	1	100-A60	100-A60	100-A60
Pivot Set	1	21EP	21EPB	21EPB-A
Hinge	15	282SS		
Screen Hinges	12		135SS	135SS
Screen Hinge Handle	3		136SS	136SS
Hanger - Intermediate	2	21SS/EN	53SS/4EN	53EN/4-A
Hanger - End	1	21SS/EN	53SSEN	52EN-A
Guide	3	106E/94	113RB/94	21ER-A
Flush Bolt - Bottom	3	360E	FFB85SS	FFB85SS
Flush Pull	3	401		
Channel	1	94PPA-A40	94A-A40	94A-A40
6 Panel Unit 'Floating'	Quantities	Product Codes		
Track	1	100-A60	100-A60	100-A60
Hinge	15	282SS		
Screen Hinges	12		135SS	135SS
Screen Hinge Handle	3		136SS	136SS
Hanger - Intermediate	2	21SS/EN	53SS/4EN	53EN/4-A
Hanger - End	2	21SS/EN	53SSEN	52EN-A
Guide	4	106E/94	113RB/94	21ER-A
Flush Bolt - Top	3	360		
Flush Bolt - Bottom	3	360E	FFB85SS	FFB85SS
Flush Pull	3	401		
Channel	1	94PPA-A60	94A-A60	94A-A60

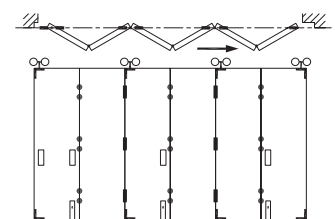
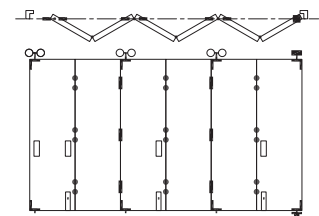
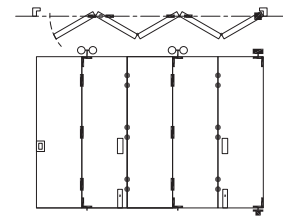
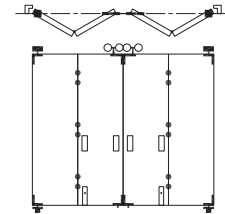
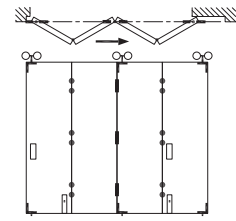

Application

Suitable for residential and light commercial folding shutters, with all panels of equal width. Panels can fold to one or both sides of the opening.

Pivot hardware enables folding exterior shutter to be designed using equal width panels with no cutting down of the panel adjacent to post.

To cover any width opening, any number of folding units can be used.

Panel Specification

Track System:	Shutterfold 25
Max Panel Height	2400mm
Max Panel Weight	25kg
Max Panel Width	900mm
Min Panel Thickness	35mm

Units of up to six panels can be pivoted to each side of the opening.

A guide system across the floor must be used on units of three panels or more. Floating units consist of four or six panels.

Shutters should be constructed to provide secure fitting for the pivot sets, hangers, hinges and guides.

Standard Packs

Pack No.	Hardware For	Contents
SF25-2PKNC	2 Panel (No Channel)	Pivot, hanger, door stop, three hinges, all timber screws and instructions.
SF25-2PK	2 Panel Pack	Pivot, hanger, door stop, guide, three hinges, all timber screws and instructions.
SF25-4PK	4 Panel Pack	Pivot, two hangers, door stop, two guides, nine hinges, all timber screws and instructions.
SF25-6PK	6 Panel Pack	Pivot, three hangers, door stop, three guides, fifteen hinges, all timber screws and instructions.
SF25-APK	2 Panel Add-on Pack	Hanger, guide, six hinges, all timber screws and instructions

Hardware Specification

Track:	100
Material	Aluminium, Clear Anodised
Standard Lengths	2000mm, 3000mm, 4000mm and 6000mm

Bracket (Face Fix):	
Bracket 316 Stainless Steel	1SS/250
Brackets located close together at the pivot end of the track with other brackets at 400mm centres.	

Hangers:	
End & Intermediate	21SS/EN
Hangers are fitted with nylon wheels on precision stainless steel ball race bearings. Vertical adjustment is simple and positive.	

Guide:	106E/94
Stainless steel plate with precision bearing	

Hinge:	282SS
Stainless steel hinge for 19mm minimum panel thickness, 65mm tall, non-mortice	

Channels:	
Aluminium	94A
Polypropylene & Aluminium	94PPA
Finish	Mill or clear anodised
Brass	94B
Standard Lengths	2000mm, 3000mm, 4000mm and 6000mm

Accessories:	
Flush Bolts	456
Flush Pulls	401

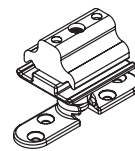
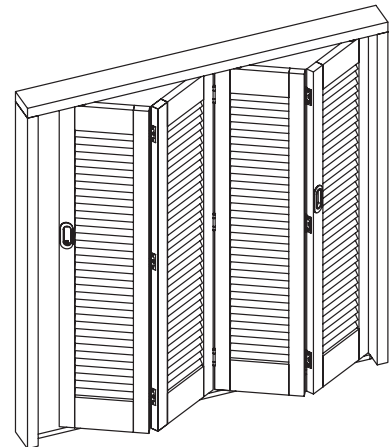

No. 21EP
PIVOT

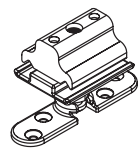

No. 21EPNC
PIVOT

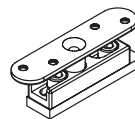

No. 21SS/EN
HANGER

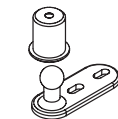

No. 106E/94
GUIDE

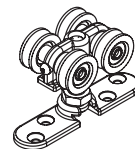

No. 282SS
HINGE



No. 20DS
DOOR STOP

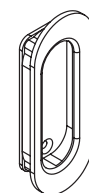
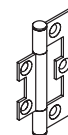

No. 401
FLUSH PULL

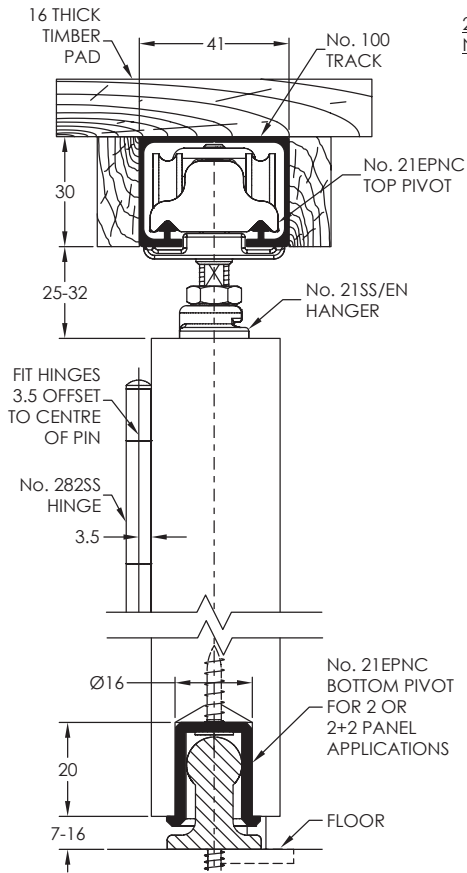

**No. 21EP
ADJUSTABLE BOTTOM PIVOT**

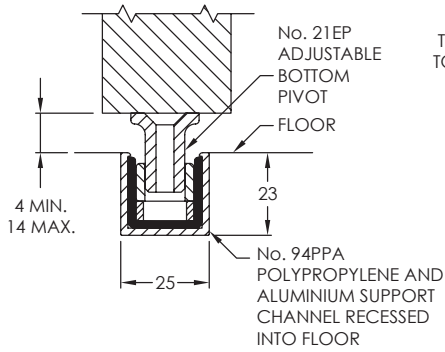

**2 OR 2+2 PANEL:
NO GUIDE AND CHANNEL**

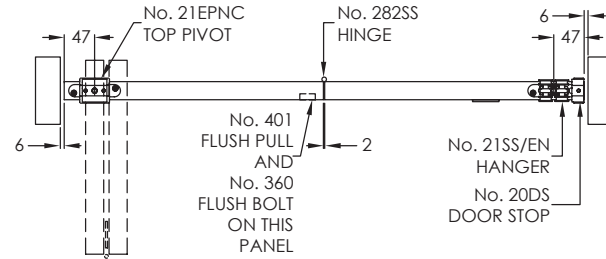
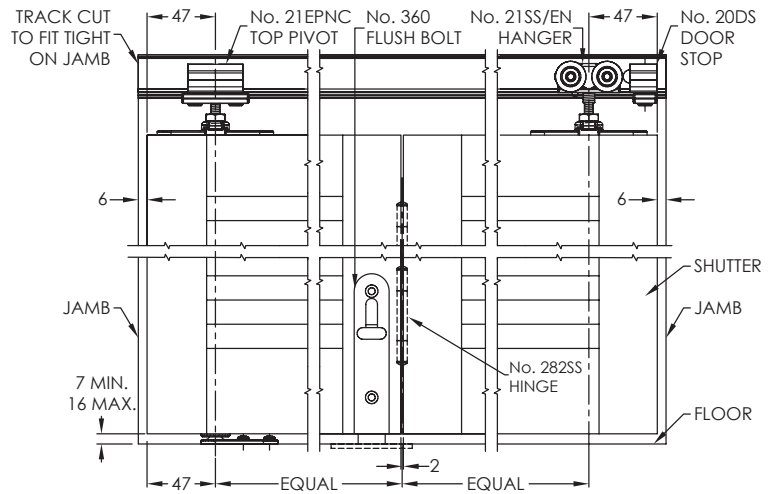

**4 OR MORE PANELS:
GUIDE AND BOTTOM CHANNEL**

