

This Guide to Quantities is only applicable to Data Sheet E106.

Specification for Individual Panels

Track System	Weatherfold 4s 50F
Refer to Data Sheet	E106
Max Panel Height	2600mm
Max Panel Weight	50kg
Max Panel Width	820mm
Min Panel Thickness	35mm
Max Number of Panels	4 each direction

2 Panel Unit

	Quantities	Product Codes
Track	1	180-A20
Pivot Set	1	BWS1F-75H
Hinge Handle Set	1	BW3-100H
End Hanger Set	1	BWS2F-50SH/M*
Flush Bolt Top	1	456R*
Flush Bolt Bottom	2	456RE*

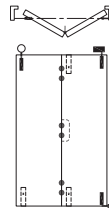

4 Panel Unit

	Quantities	Product Codes
Track	1	180-A40
Pivot Set	1	BWS1F-75H
Hinge Handle Set	2	BW7-100H
Intermediate Hanger Set	1	BWS4F-50SH
End Hanger Set	1	BWS2F-50SH/M*
Flush Bolt Top	2	456R*
Flush Bolt Bottom	4	456RE*

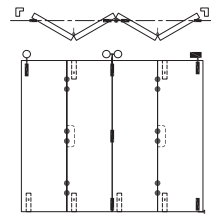

2 + 2 Panel Unit

	Quantities	Product Codes
Track	1	180-A40
Pivot Set	2	BWS1F-75H
Hinge Handle Set	2	BW3-100H
End Hanger Set	2	BWS2F-50SH/M*
Flush Bolt Top	2	456R*
Flush Bolt Bottom	4	456RE*

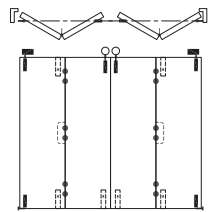

*Note, for aluminium systems only use BWS2F-50SH end hanger sets and replace 456R and 456RE flush bolts with 512 and 512E respectively.



Application

For residential and commercial folding systems where weatherproofing of the opening is required.

This section covers Weatherfold 4s 50F hardware suitable for non mortice timber applications.

Weatherfold 4s 50F hardware is designed for top hung exterior folding door systems without bottom guide.

Weatherfold 4s 50F hangers are cast 316 marine grade stainless steel with precision stainless steel bearings for enhanced corrosion resistance.

Panel Specification

Track System:	Weatherfold 4s 50F
Max Panel Height	2600mm
Max Panel Weight	50kg
Max Panel Width	820mm
Panel Thickness	35mm
Max Number of Panels	4 each direction

Hardware Specification

Track:	180
Material	Aluminium, Clear Anodised
Standard Lengths	2000mm, 3000mm, 4000mm and 6000mm

Hanger Sets:	
End Hanger Set - Non Mortice	BWS2F-50SH
End Hanger Set - Mortice	BWS2F-50SM
Intermediate Hanger Set	BWS4F-50SH
Meeting Door Hanger Set - Rebate (includes 2 hangers)	BWS8F-50S

Pivot Set:	
Top and Jamb Pivots	BWS1F-75H

Hinge Sets:	
Hinge Handle Set	BW3-100H
Offset Hinge Handle Set	BW7-100H

Accessories:	
Flush Bolt Standard	456
Flush Bolt Lockable	456E
Flush Bolt Long	456L
Masonry Keeper	360RK
Frame Seal	AQ21
Door Seal	AQ48
Track Sea	PS13B

Finish options
 Hardware: (SS) Satin Stainless, (PS) Polished Stainless.
 Flush bolts: (SN) Satin Nickel, (PN) Polished Nickel.

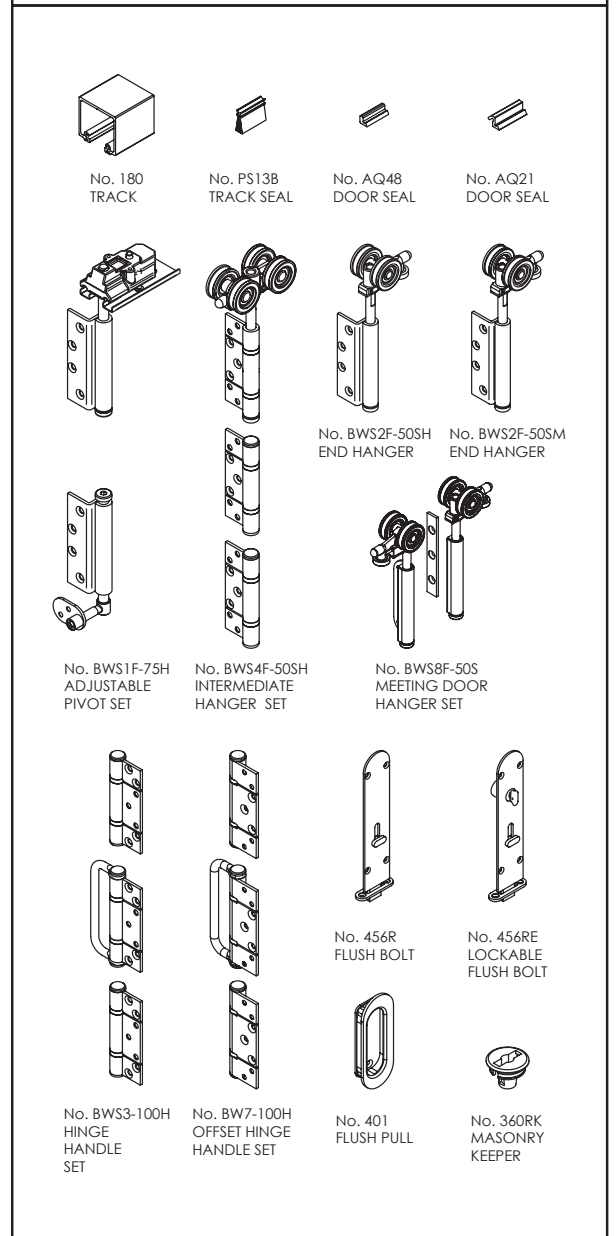
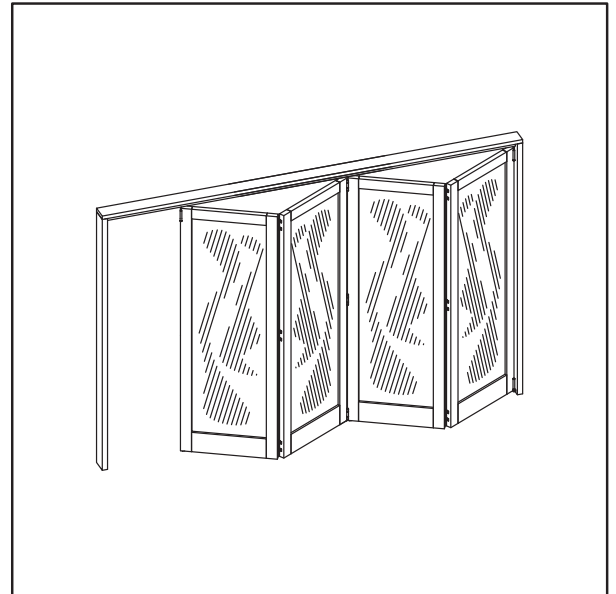

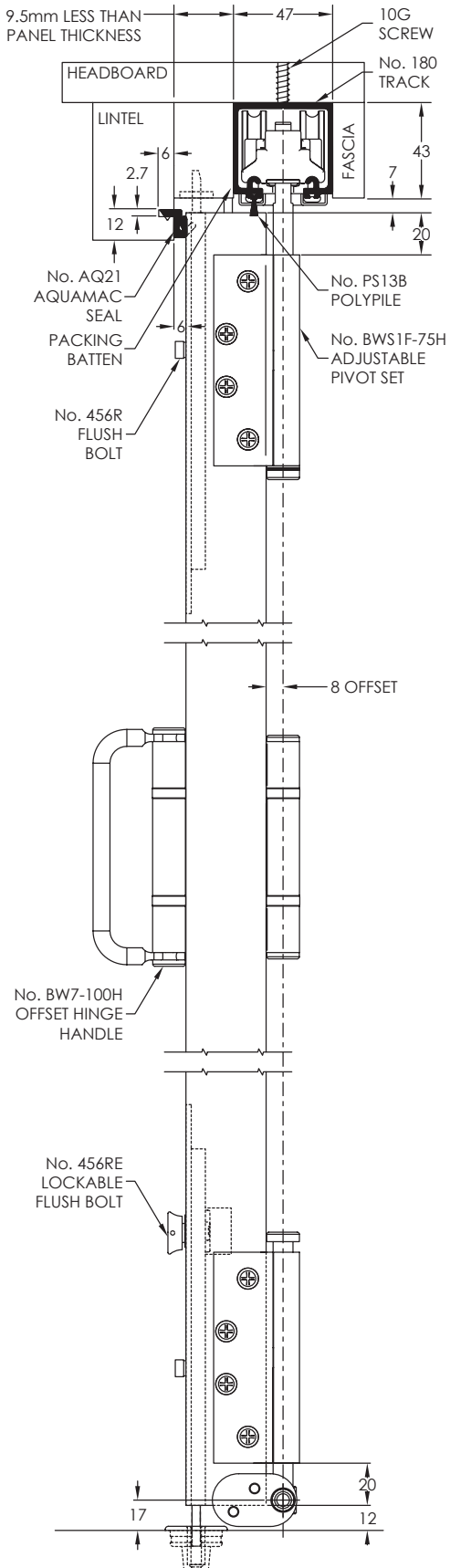

4+0 PANEL OUTWARD OPENING SYSTEM - CLOSED
(SHOWN WITHOUT TRACK OR HEAD SECTION)

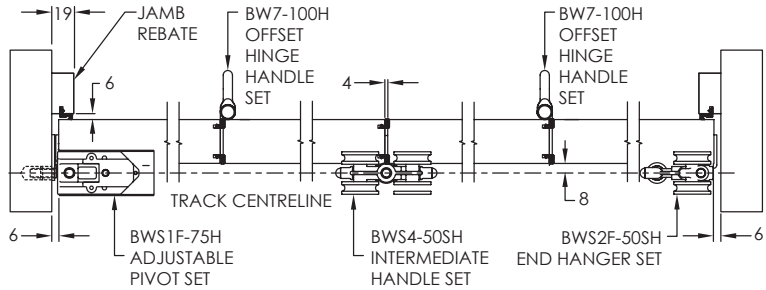

4+0 PANEL OUTWARD OPENING SYSTEM - OPEN
(SHOWN WITHOUT HEAD SECTION)

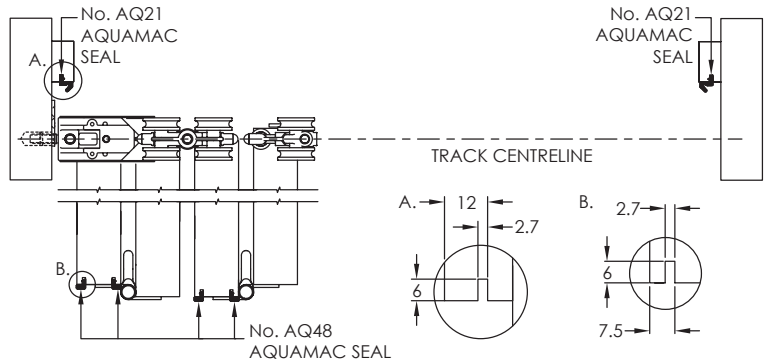

4+0 PANEL OUTWARD OPENING SYSTEM - CLOSED
(TYPICAL OUTSIDE ELEVATION)

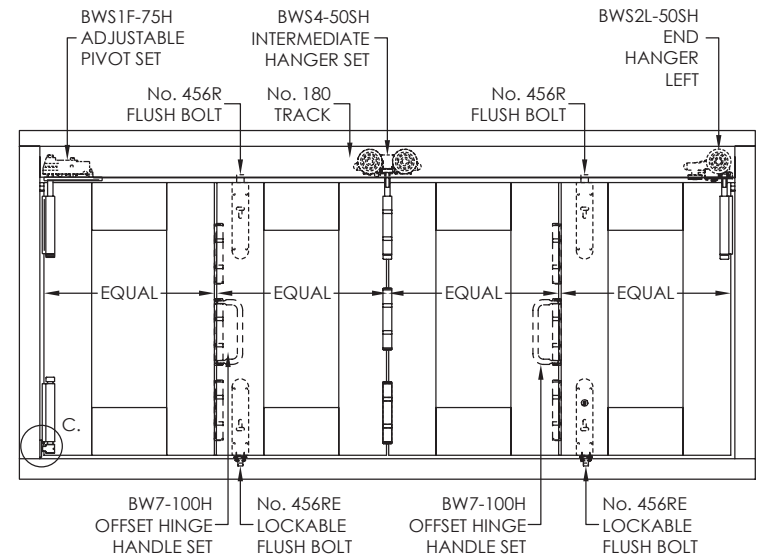

THE 6mm GAP MAY BE REDUCED TO 3mm BY CHECKING IN THE JAMB MOUNTING PLATE

