

Application

Designed to achieve minimal clearances of just 4.5mm between the top edge of the panel and underside of the track concealing all moving parts.

Ideally suited for floor to ceiling straight sliding timber panels in both residential and commercial applications.

Zero Clearance 350 hangers are cast 316 stainless steel with stainless steel bearings and suitable for both interior and exterior and exterior applications.

Panel Specification

Track System:	Zero Clearance 350
For Individual Panels:	
Max Panel Height	3300mm
Max Panel Weight	350kg
Min Panel Thickness	40mm

For ease of operation it is recommended that the panel width should not exceed 75% of panel height.

Timber panels for interior use can be flush construction or glazed.

Hardware Specification

Track:	350
Material	Aluminium
Finish	Mill or clear anodised
Standard Lengths	2000mm, 3000mm, 4000mm and 6000mm

Hangers:	Stainless Option
Timber panels	61/HN 61SS/HN

Stainless steel hangers are fitted with nylon tyre wheels on precision stainless steel ball bearings. Vertical adjustment is simple and positive.

Hanger supplied with timber screws, fixing plate and nylon tyred precision bearings. Vertical adjustment is simple and positive. Nylon tyre wheel hangers should not be used on installations involving temperatures exceeding 80°C.

Guides:	
Timber panels - SS plate fitting	106RB/94
Multiple panels - bearing	106A/94
Multiple panels - T slot	106AT

Channels:	
Aluminium	94A Mill or clear anodised
Aluminium & Polypropylene	94PPA Mill or clear anodised
Brass	94B
Standard lengths	2000mm, 3000mm, 4000mm and 6000mm

Accessories:	
Door Collector - multiple panels	924-DC
Door Stop	180DS
Flush Pulls	401
Flush Bolts	456

Flush bolts and flush pulls are available in (PVDB) PVD Brass, (SN) Satin Nickel & (PN) Polished Nickel

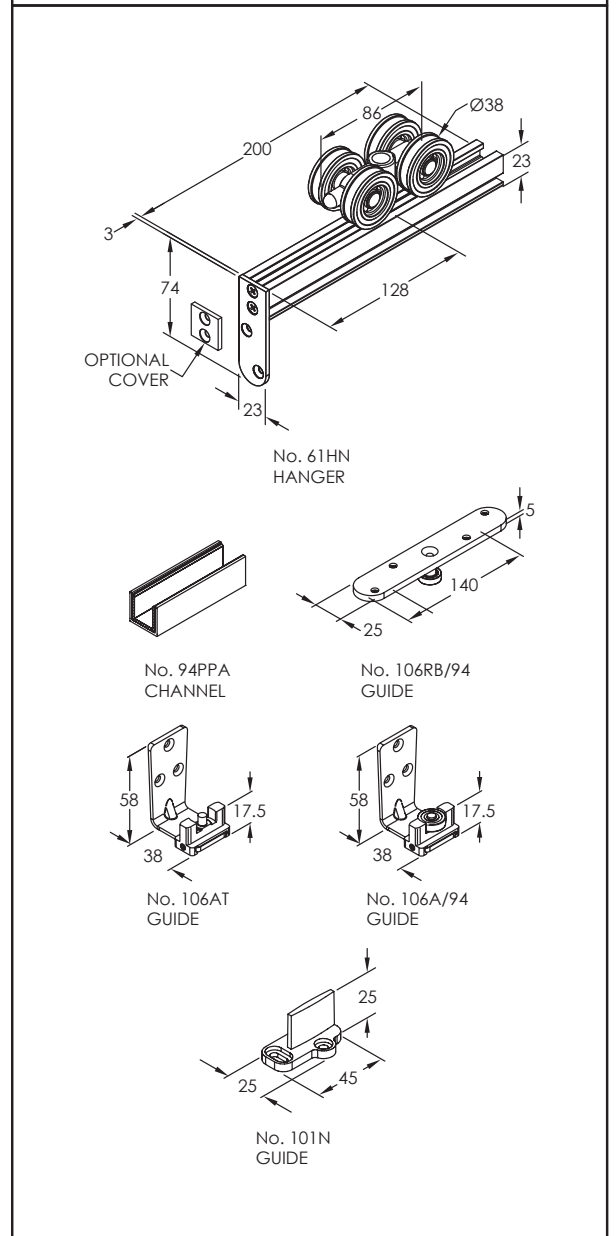
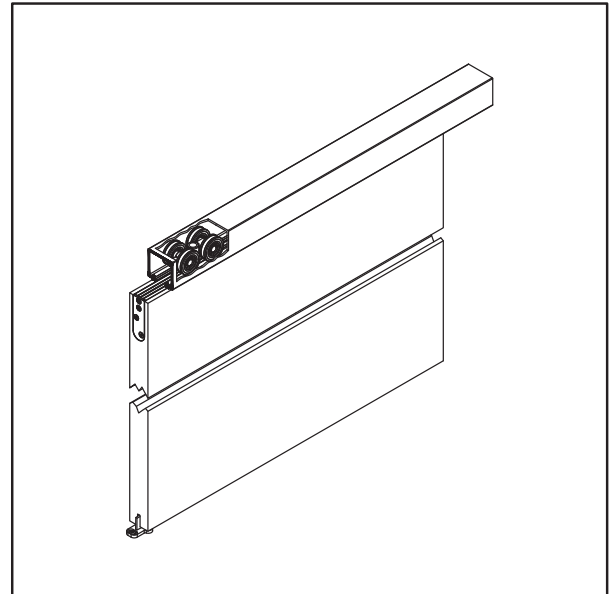

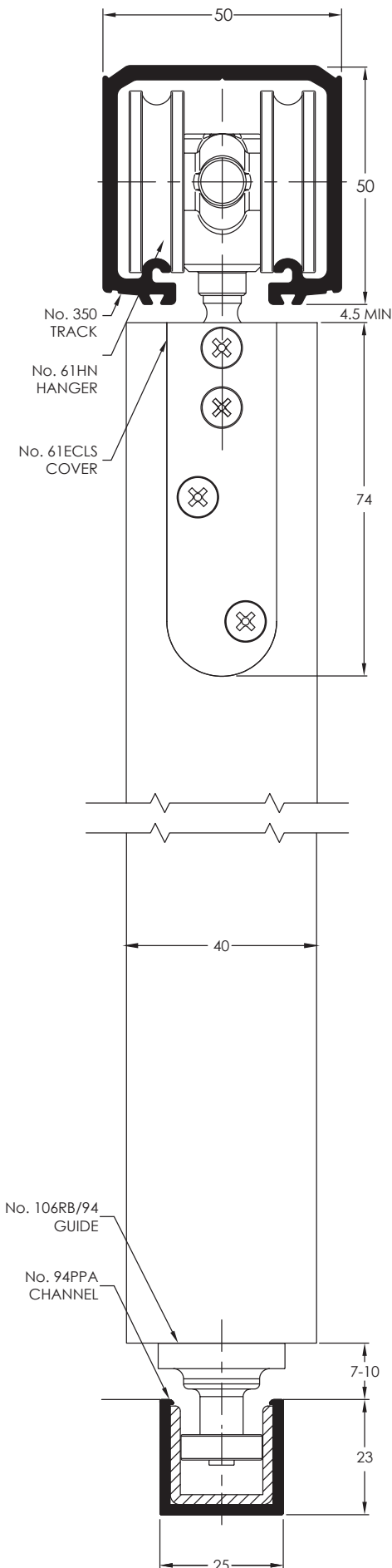

TRACK FIXING CENTRES
35mm FROM EACH END, THEN FIX AT 400mm INTERVALS

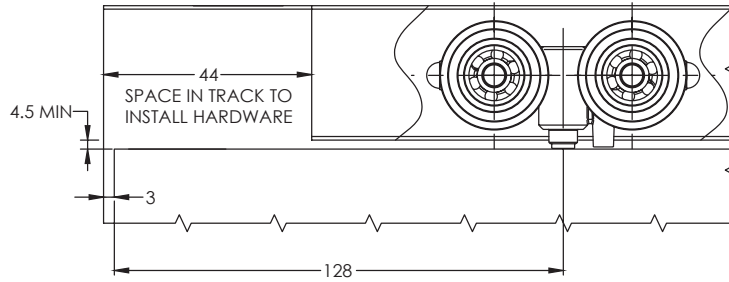

PANEL PREPARATION AND INSTALLATION

1. PREPARE PANEL FOR MOUNTING PLATE.

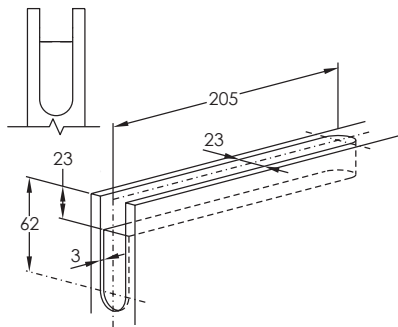

2. FIT MOUNTING PLATE WITH SCREWS SUPPLIED

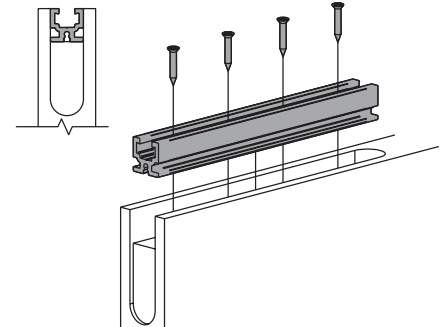

ASSEMBLY

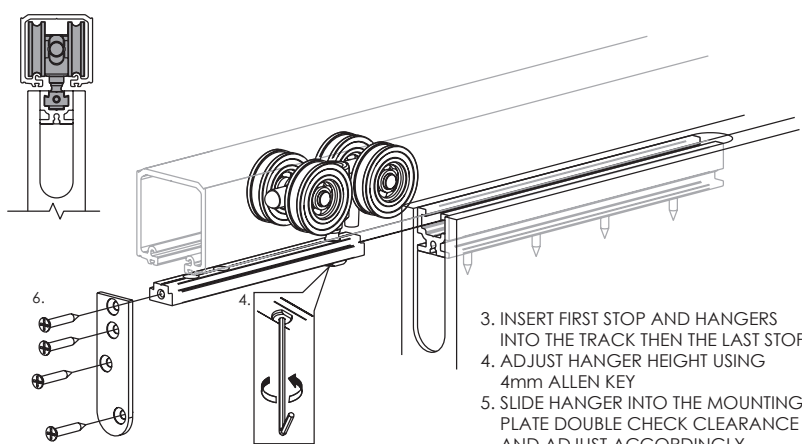

3. INSERT FIRST STOP AND HANGERS INTO THE TRACK THEN THE LAST STOP
4. ADJUST HANGER HEIGHT USING 4mm ALLEN KEY
5. SLIDE HANGER INTO THE MOUNTING PLATE DOUBLE CHECK CLEARANCE AND ADJUST ACCORDINGLY
6. ONCE HEIGHT IS CORRECT AND PANEL IS LEVEL, FIX COVER ONTO THE PANEL

GUIDE OPTION

