

Application

Suitable for interior, top hung sliding panels.

Ideal for sliding panels and shutters in residential and commercial applications. Versatile design allows the opening to be covered by any number of panels.

The aluminium track may be fitted directly to the lintel, in single or multiple lines, or face fitted to the lintel using a single line of brackets or the specifically designed face fix track. Pelmet accessory with end caps also available.

Hangers come standard with a steel bracket and four nylon tyred wheels with precision bearings. Clip stops provided but can be upgraded to a soft close device for improved operation.

Panel Specification

Track System:	Zero Clearance 60
For Individual Panels:	
Max Panel Weight	60kg
Max Panel Height	2400mm
Min Panel Thickness	28mm

Standard Sets and Packs

Sets comprise of top track, brackets or face fix track, hangers, clip stops or soft closes, guide, spanner and timber screws.

Set No.	Panel width	Track Length	Qty Brackets
ZC60-20/1	610mm to 915mm	2000mm	5
ZC60-30/1	915mm to 1525mm	3000mm	8
ZC60-S20/1	610mm to 915mm	2000mm	5
ZC60-S30/1	915mm to 1525mm	3000mm	8
ZC60F-S20/1CA	610mm to 915mm	2000mm	Face Fix track
ZC60F-S20/1PWT	610mm to 915mm	2000mm	Face Fix track

Kits with Face fix tracks available with clear anodised or powder coat white pelmets. Other colours also available upon request.

Pack No.	
ZC60-1PK	Fitting pack only, no track and brackets

Hardware Specification

Track:	60A
Standard lengths	2000mm, 3000mm, 4000mm and 6000mm
Material	Aluminium, Mill

Brackets:	
Single	91
Pack of 5 brackets	91/5

Bracket 91 made from stainless steel. Supplied with matching fasteners.

Hangers (2 per panel):

Hanger	609
--------	-----

Hanger designed for 60CS for has a nylon body and comes with an extended, zinc plated steel bracket and four nylon tyred wheels with chrome precision bearings.

Hanger	610
--------	-----

Hanger designed for 60SCT has a nylon body and comes with a short, zinc plated steel bracket and four nylon tyred wheels with chrome precision bearings.

Clip Stops:	60CS
--------------------	------

Adjustable clip stop made from POM, an engineered thermoplastic.

Guide:	55G
---------------	-----

Guide in white nylon, comes in two parts that fit on both sides of the panel. The guide is floor mounted.

Accessories:

Soft Close	60SCT
------------	-------

Suitable for panels up to 60 kg.

Pelmet and End Caps	64
---------------------	----

Aluminium pelmet available in 2000mm and 3000mm lengths in powder coat white or clear anodised.

Alternative Guide	801
-------------------	-----

Spring loaded guide, nylon body and tip with zinc plated steel shaft. Designed to slide in the 92 and 130 thresholds.

Alternative Guide	101N
-------------------	------

The nylon guide is designed to slide through a 20mm deep by 5mm wide sawcut in the bottom rail of the panel.

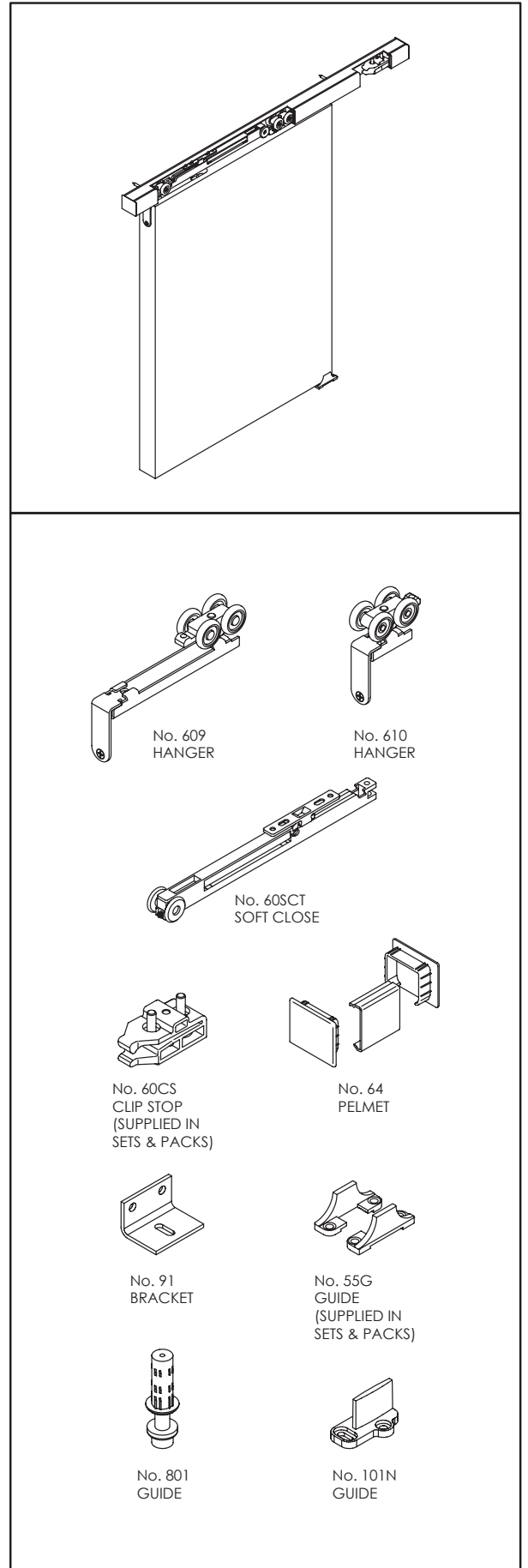

91LS BRACKETS

Track Length	2000	3000	4000	6000
Bracket Qty.	5	8	10	15

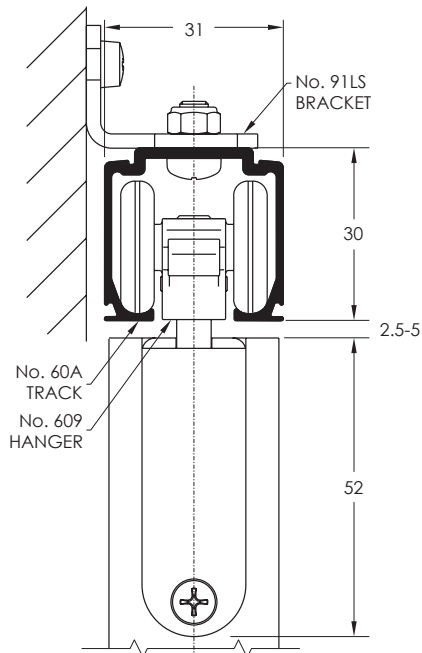

TRACK & BRACKET FIXING CENTRES

USING 8G SCREWS, 50mm FROM EACH END, THEN SPACED AT APPROX 450mm INTERVALS

POSITION 1 (CLIP STOP)

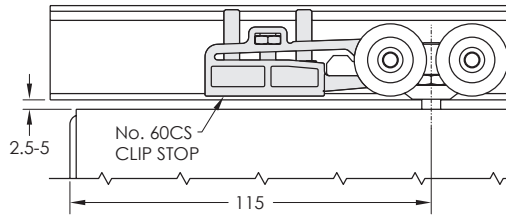

POSITION 2 (SOFT CLOSE)

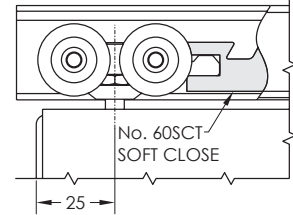

PANEL PREPARATION AND INSTALLATION

1. PREPARE PANEL FOR MOUNTING PLATE.
2. FIT MOUNTING PLATE WITH SCREWS SUPPLIED

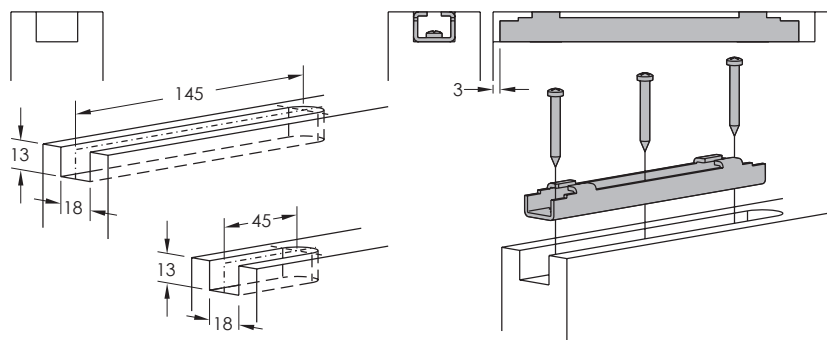

ASSEMBLY

3. INSERT FIRST CLIP STOP & HANGERS INTO THE TRACK. THEN THE LAST CLIP STOP
4. ADJUST HANGER HEIGHT BY ROTATING THE BOLT WITH THE HANGER PLATE
5. SLIDE HANGER INTO THE MOUNTING BRACKET. DOUBLE CHECK CLEARANCE & ADJUST ACCORDINGLY
6. ONCE HEIGHT IS CORRECT & PANEL IS LEVEL, FIX PLATE TO THE PANEL

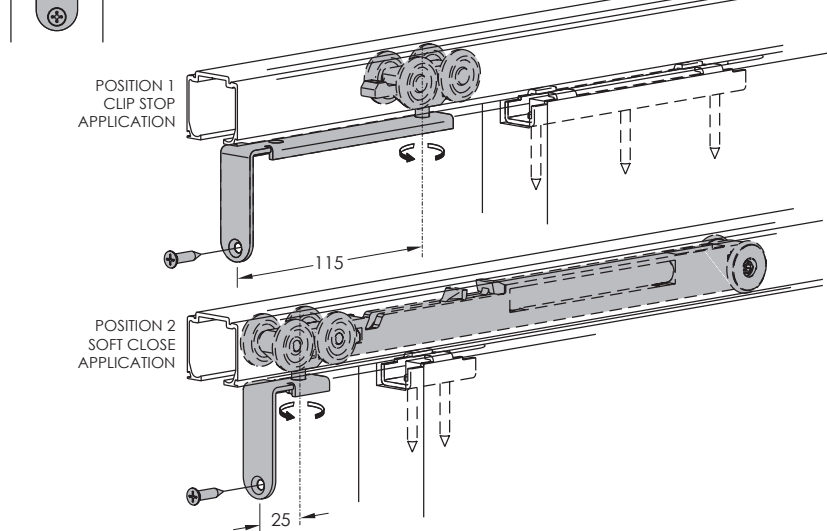

ALTERNATIVE GUIDES

