

### Application

Designed to achieve minimal clearances of just 2.5mm between the top edge of the panel and underside of the track concealing all moving parts.

Ideally suited for floor to ceiling straight sliding timber panels in both residential and commercial applications.

The smooth track profile can be easily recessed into ceiling to further enhance the clean-lines of the applications.

### Panel Specification

Track System:	Zero Clearance 80
For Individual Panels:	
Max Panel Height	3000mm
Max Panel Weight	80kg
Min Panel Thickness	32mm

For ease of operation it is recommended that the panel width should not exceed 75% of panel height.

Timber panels for interior use can be flush construction or glazed.

### Standard Sets and Packs

Sets comprise of top track, hangers, clip stops, nylon guides and timber screws.

Set No.	Max. Panel Width	Track Length	Material
ZC80-20/1	950mm	2000mm	Chrome bearings, mill track
ZC80SS-20/1	950mm	2000mm	SS bearings, anodised track
ZC80-30/1	1450mm	3000mm	Chrome bearings, mill track
ZC80SS-30/1	1450mm	3000mm	SS bearings, anodised track

Pack No.	
ZC80-1PK	Fitting pack only, no track
ZC80SS-1PK	Fitting pack only, no track, SS bearings

### Hardware Specification

<b>Track:</b>	100
Material	Aluminium
Finish	Mill or clear anodised
Standard lengths	2000mm, 3000mm, 4000mm and 6000mm

<b>Hangers:</b>	Stainless Option
Timber panels	61ENP 61SS/ENP

Hangers supplied with fixing plate and nylon tyred precision bearings. Vertical adjustment is simple and positive. Nylon tyre wheel hangers should not be used on installations involving temperatures exceeding 80°C.

Guides:	
Timber panels - SS plate (94 channels)	106E/94
Timber panels - SS plate (96W channel)	106SSMF
Timber panels - nylon guide	101N
Multiple panels - bearing	106A/94
Multiple panels - T slot	106AT
Nylon, spring loaded	108N/814
Stainless and nylon, spring loaded	801S

Channels:	
Aluminium & Polypropylene	94PPA Mill or clear anodised
Aluminium	814A Rail anodised
	94A Mill or clear anodised
	96W Clear anodised
Standard lengths	2000mm, 3000mm, 4000mm and 6000mm
Aluminium	81 Channel anodised
Standard lengths	1200mm, 1500mm, 1800mm, 2400mm and 3600mm

Accessories:	
Door Collector - multiple panels	924-DC
Soft Close	100SCT
Clip Stop	100CS
Flush Pulls	401
Flush Bolts	456
Flush bolts and flush pulls are available in (PVDB) PVD Brass, (SN) Satin Nickel & (PN) Polished Nickel	

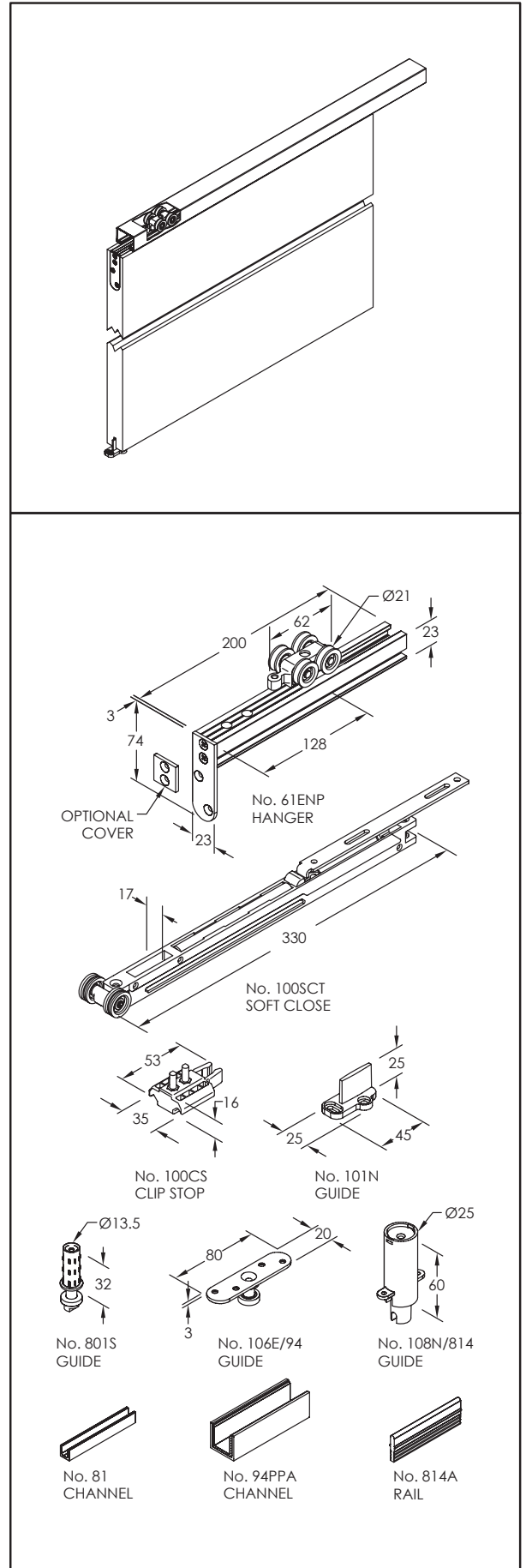

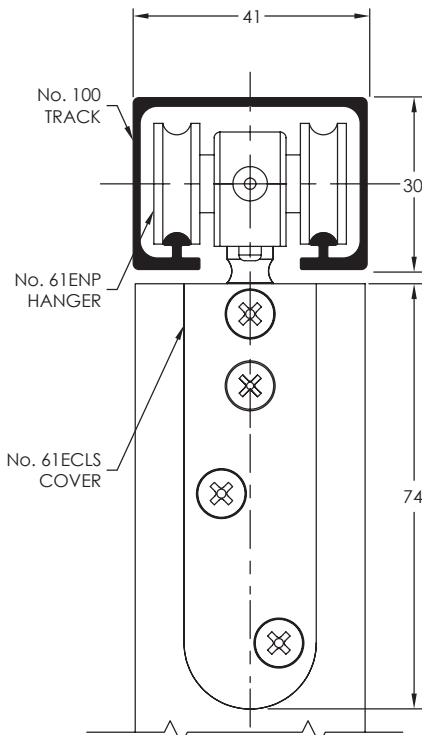

**TRACK FIXING CENTRES**  
35mm FROM EACH END, THEN FIX AT 400mm INTERVALS

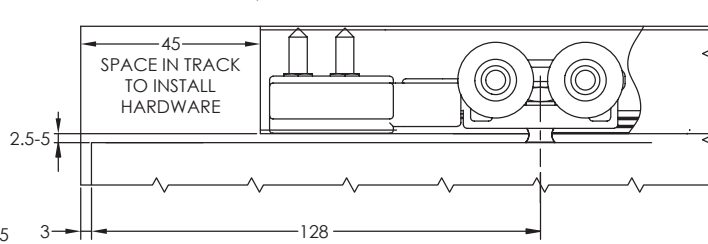

**PANEL PREPARATION AND INSTALLATION**

1. PREPARE PANEL FOR MOUNTING PLATE.

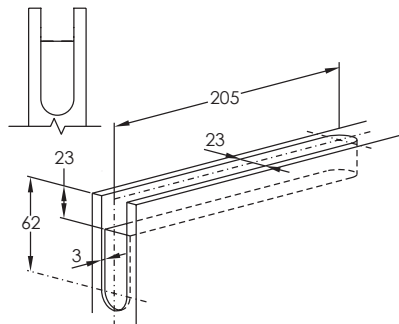

2. FIT MOUNTING PLATE WITH SCREWS SUPPLIED

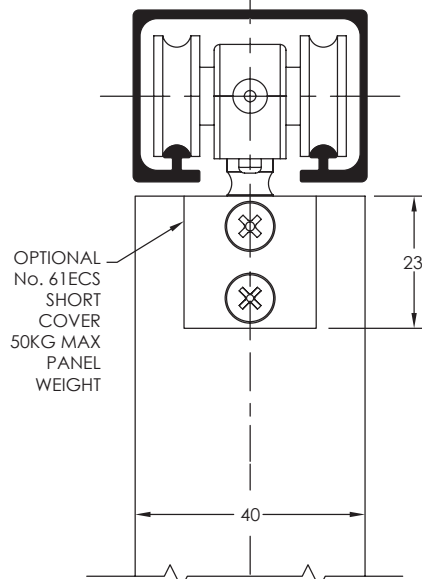
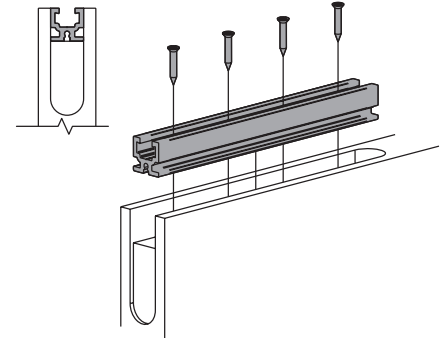

OPTIONAL  
No. 61ECS  
SHORT  
COVER  
50KG MAX  
PANEL  
WEIGHT

**ASSEMBLY**

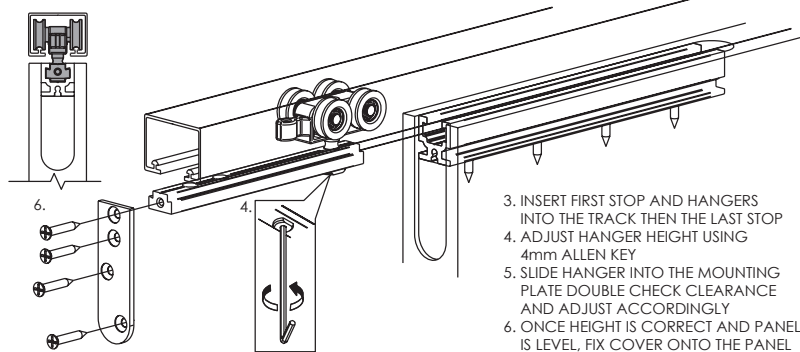

3. INSERT FIRST STOP AND HANGERS INTO THE TRACK THEN THE LAST STOP
4. ADJUST HANGER HEIGHT USING 4mm ALLEN KEY
5. SLIDE HANGER INTO THE MOUNTING PLATE DOUBLE CHECK CLEARANCE AND ADJUST ACCORDINGLY
6. ONCE HEIGHT IS CORRECT AND PANEL IS LEVEL, FIX COVER ONTO THE PANEL

**OPTIONAL GUIDES**

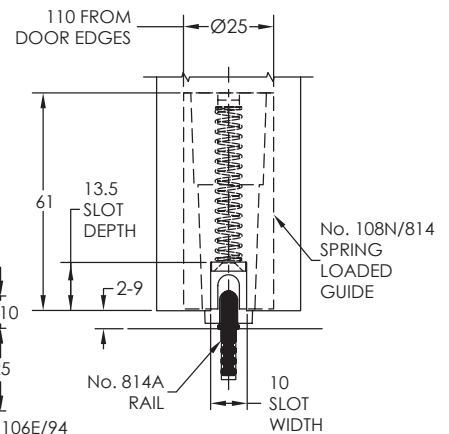
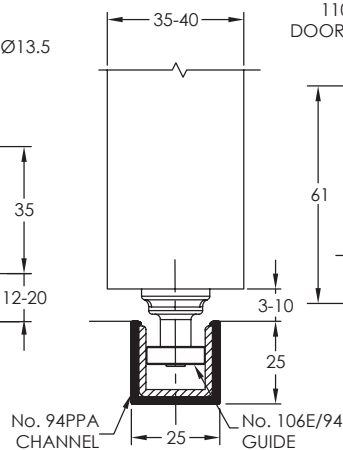
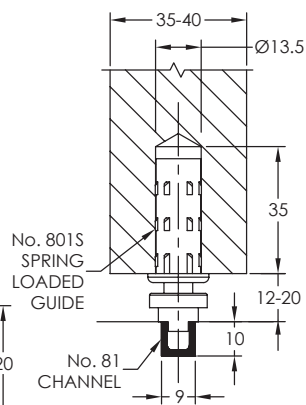
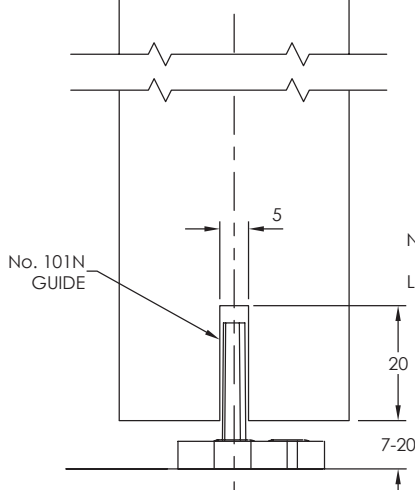

\* WHEN USING No. 100SCT SOFT CLOSE, 620 MIN PANEL WIDTH SINGLE SOFT CLOSE, 820 MIN PANEL WIDTH DOUBLE SOFT CLOSE