

### Applications

Brio's Open Bar Rail Timber is an ideal internal system for residential and commercial applications of timber panels with face fix hangers and flat bar rail.

Open Bar Rail Timber 80 hangers use precision bearings with nylon tyre.

### Panel Specification

Track System:	Open Bar Rail Timber 80
For Individual Panels:	
Max Panel Height	3000mm
Max Panel Width	1100mm
Max Panel Weight	80kg
Panel Thickness	35-44mm

### Standard Sets

Sets include hangers, door stops, guide, brackets, fixings and rail.

Set No.	Max. Panel Width	Rail Length	Material
OBF80-20	850mm	2000mm	Stainless steel
OBF80-20PB	850mm	2000mm	Mild steel powder coat black
OBF80-25	1100mm	2500mm	Stainless steel
OBF80-25PB	1100mm	2500mm	Mild steel powder coat black

### Hardware Specification

Alternative Guides:	
Timber panels - SS plate (94 channels)	106E/94
Timber panels - SS plate (96W channel)	106SSMF
Timber panels - nylon guide	101N
Multiple panels	102W/94SS
Nylon spring loaded guide	108N/814

  

Channels:	
Aluminium & Polypropylene	94PPA Mill or clear anodised
Aluminium	94A Mill or clear anodised
	96W Clear anodised
	814A Rail anodised
Standard lengths	2000mm, 3000mm, 4000mm and 6000mm

Bracket:	
Joining bracket	80B-JB or 80B-JBPB

Accessories:	
Open Bar Rail Timber 80kg soft close	OBF80-SCT

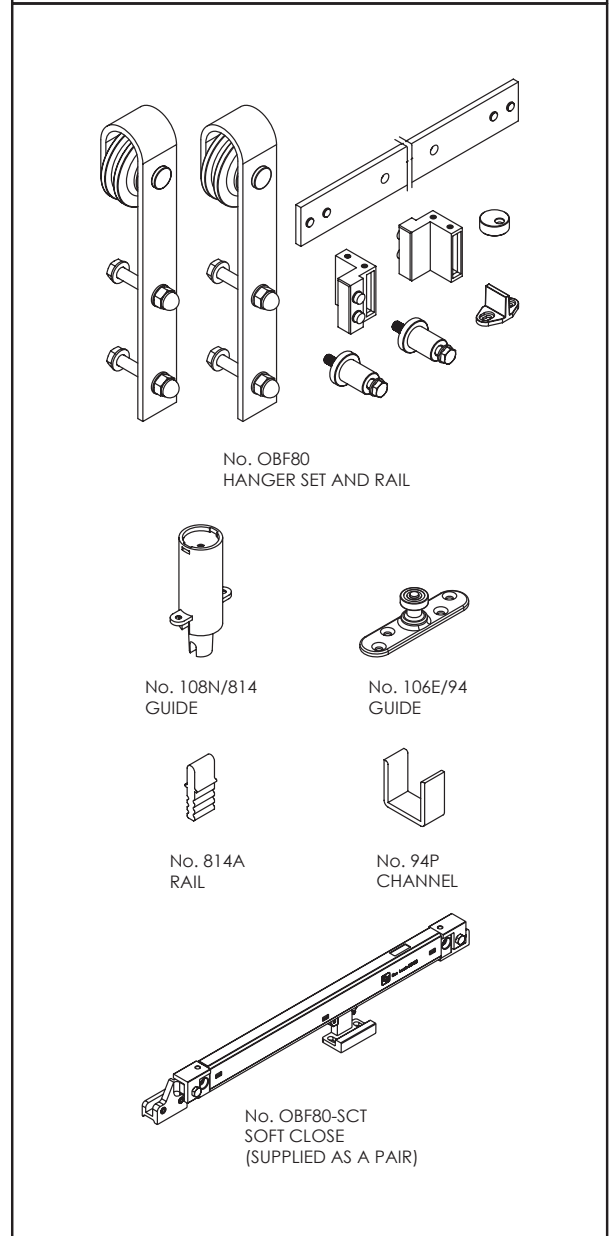
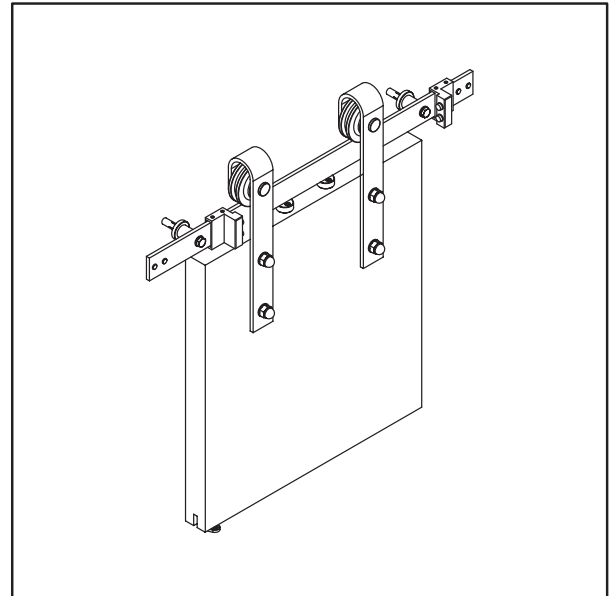

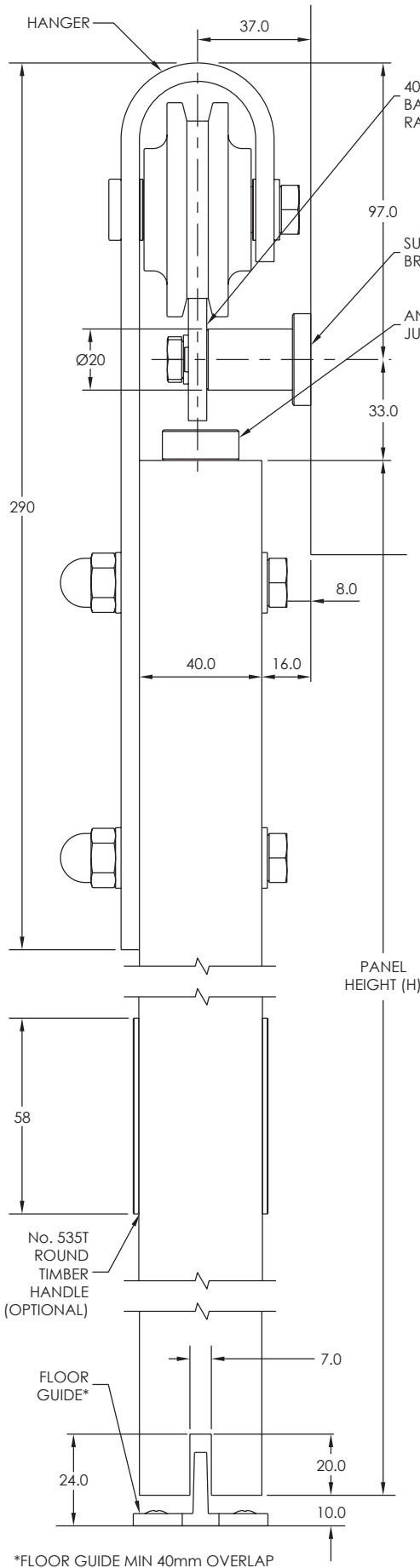

### BRACKET PLACEMENT

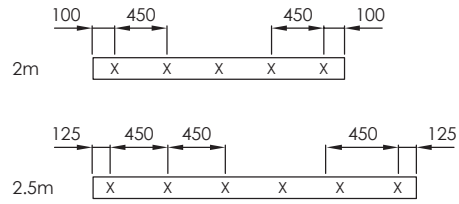

### DOOR PREPARATION

HANGERS (INSIDE FACE OF DOOR SHOWN)  
 A = STANDARD NUT AND BOLT OPTION PILOT HOLE Ø10.0 X 4  
 COACH SCREW PILOT HOLE Ø8.0 X 4

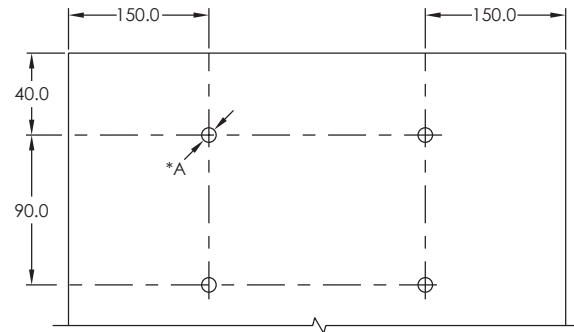

### SOFT CLOSE (OPTIONAL)

### ROUND TIMBER HANDLE (OPTIONAL)

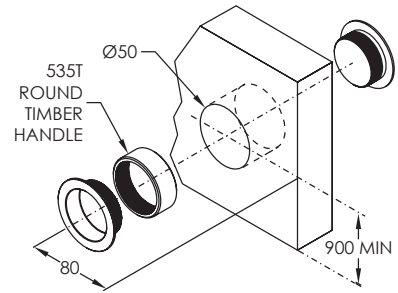
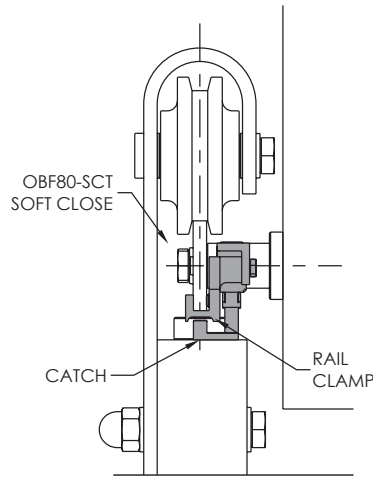

### OPTIONAL GUIDES

