

This Guide to Quantities is only applicable to Data Sheets D200.

Specification for Individual Panels

Track System	Interfold 25
Max Panel Height	2600mm
Max Panel Weight	25kg
Max Panel Width	1000mm
Min Panel Thickness	35mm
Max Number of Panels	6 each direction

2 Panel Unit

	Quantities	Product Codes
Track	1	100-20
Pivot Set	1	BWS1F-25H
Hinge Handle Set	1	BW3-25H
End Hanger Set	1	BWS2 (L or R)-25CH
Guide	1	96W-A20
Flush Bolt Top	1	360
Flush Bolt Bottom	1	360E

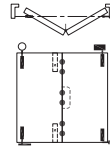

3 Panel Unit

	Quantities	Product Codes
Track	1	100-30
Pivot Set	1	BWS1F-25H
Offset Hinge Handle Set	1	BW7-25H
Intermediate Hanger Set	1	BWS4-25CH
Guide	1	96W-A30
Flush Pull	1	401
Flush Bolt Top	2	360
Flush Bolt Bottom	2	360E

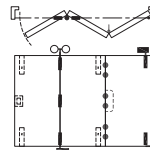

4 Panel Unit

	Quantities	Product Codes
Track	1	100-40
Pivot Set	1	BWS1F-25H
Offset Hinge Handle Set	2	BW7-25H
Intermediate Hanger Set	1	BWS4-25CH
End Hanger Set	1	BWS2 (L or R)-25CH
Guide	1	96W-A40
Flush Bolt Top	2	360
Flush Bolt Bottom	2	360E

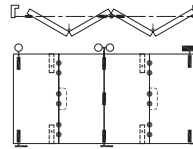

2+2 Panel Unit

	Quantities	Product Codes
Track	1	100-40
Pivot Set	2	BWS1F-25H
Hinge Handle Set	2	BW3-25H
End Hanger Set	1	BWS2L-25CM
End Hanger Set	1	BWS2R-25CM
Guide	1	96W-A40
Flush Bolt Top	2	360
Flush Bolt Bottom	2	360E

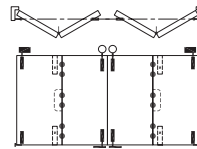

5 Panel Unit

	Quantities	Product Codes
Track	1	100-60
Pivot Set	1	BWS1F-25H
Hinge Handle Set	1	BW3-25H
Offset Hinge Handle Set	1	BW7-25H
Intermediate Hanger Set	2	BWS4-25CH
Guide	1	96W-A60
Flush Pull	1	401
Flush Bolt Top	3	360
Flush Bolt Bottom	3	360E

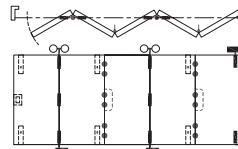

6 Panel Unit

	Quantities	Product Codes
Track	1	100-60
Pivot Set	1	BWS1F-25H
Hinge Handle Set	1	BW3-25H
Offset Hinge Handle Set	2	BW7-25H
Intermediate Hanger Set	2	BWS4-25CH
End Hanger Set	1	BWS2 (L or R)-25CH
Guide	1	96W-A60
Flush Bolt Top	3	360
Flush Bolt Bottom	3	360E

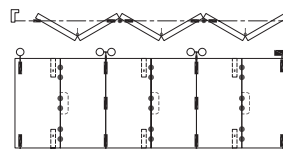



blank page

Application

For residential and commercial interior folding panels that close against rebate.

Interfold 25 hardware is suitable for timber systems, with all panels of equal width.

Specifically designed for applications where sound and light proofing is required.

Interfold 25 hangers are cast 316 marine grade stainless steel with precision chrome bearings and nylon outer tyres.

Panel Specification

Track System:	Interfold 25
Max Panel Height	2600mm
Max Panel Weight	25kg
Max Panel Width	1000mm
Min Panel Thickness	35mm

Units of up to six panels can be pivoted to each side of the opening. Units with an odd number of panels provide an access panel.

Panels should be constructed to provide secure fitting for the pivot, hanger and hinge sets. Sets include timber screws.

Track:	100
Material	Aluminium
Finish	Mill or Clear Anodised
Standard Lengths	2000mm, 3000mm, 4000mm and 6000mm

Bottom Guide Channel:	96W
Recessed Channel	Aluminium
Material	Clear Anodised
Standard Lengths	2000mm, 3000mm, 4000mm and 6000mm

Hanger Sets:	
End Hanger - Non mortice hinge	BWS2 (L or R)-25CH
End Hanger - Mortice hinge	BWS2 (L or R)-25CM
Intermediate Hanger Set	BWS4-25CH

Pivot Set:	
Top and Bottom Pivots	BWS1F-25H

Hinge Sets:	
Hinge Handle Set	BW3-25H
Offset Hinge Handle Set	BW7-25H
Hinge Set	BW5-25H
Offset Hinge Set	BW6-25H

Accessories:	
Flush Pull	401
Flush Bolt Standard	360
Flush Bolt Lockable	360E
Flush Bolt Long	360L

Finish options
 Hardware: (SS) Satin Stainless, (PS) Polished Stainless
 Flush Bolts: (SN) Satin Nickel, (PN) Polished Nickel

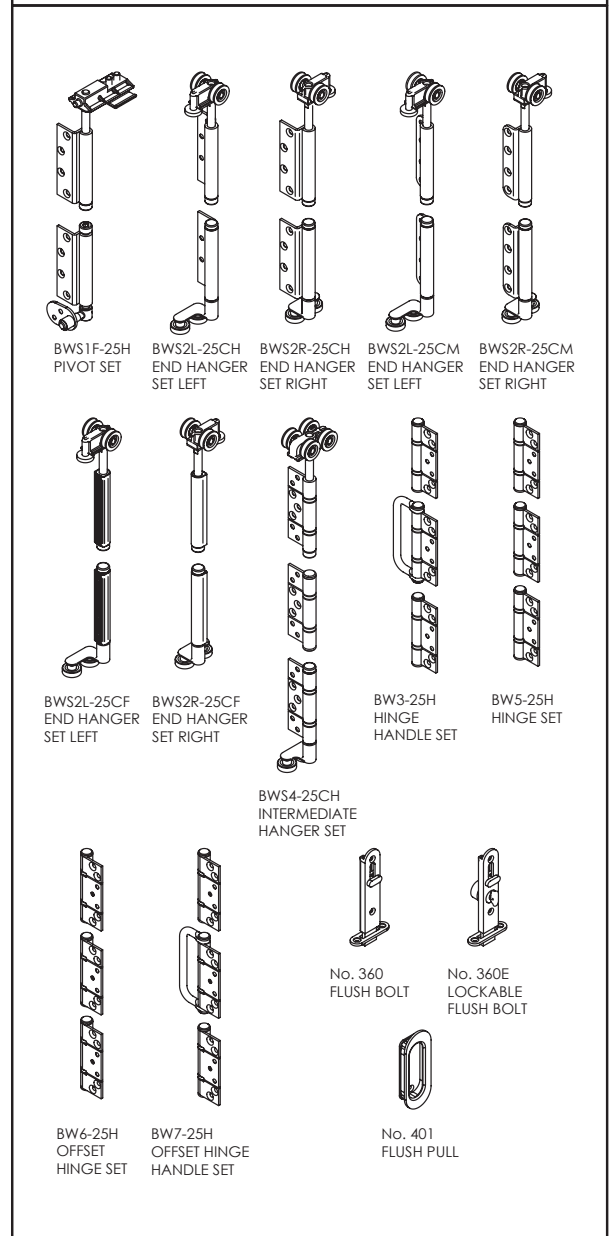
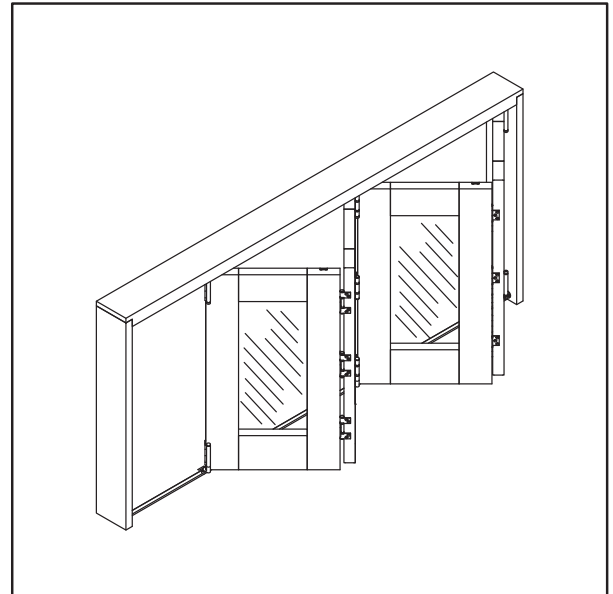

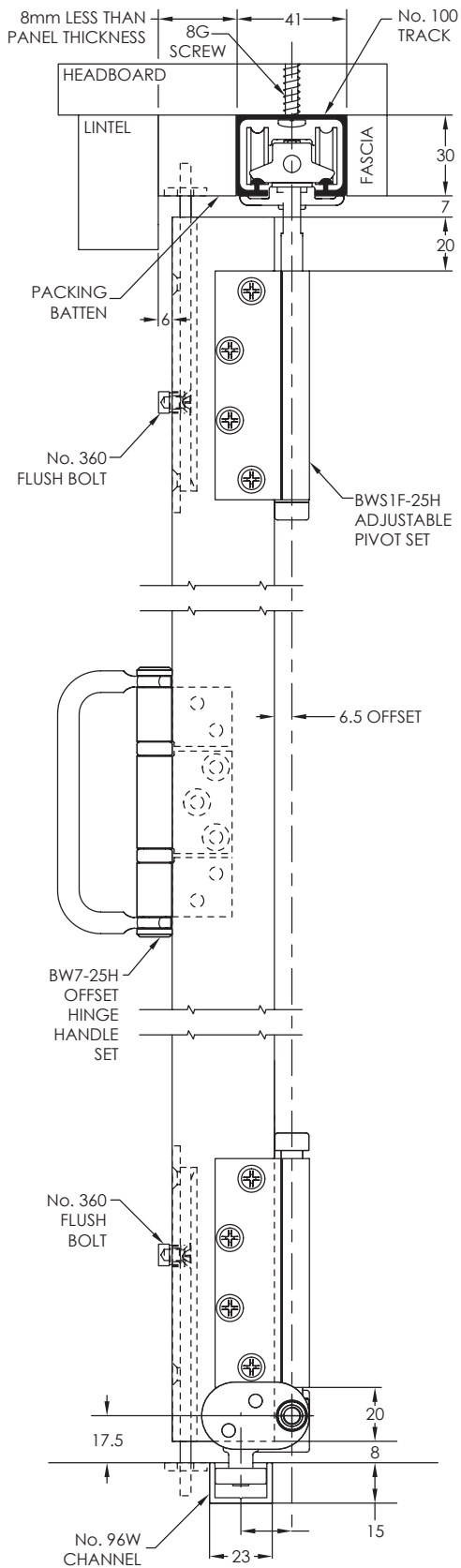

4+0 PANEL OUTWARD OPENING SYSTEM - CLOSED
(SHOWN WITHOUT TRACK, CHANNEL OR HEAD SECTION)

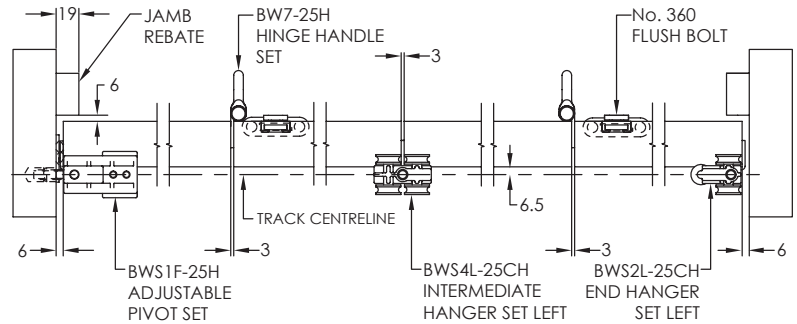

4+0 PANEL OUTWARD OPENING SYSTEM - OPEN
(SHOWN WITHOUT TRACK, SILL OR HEAD SECTION)

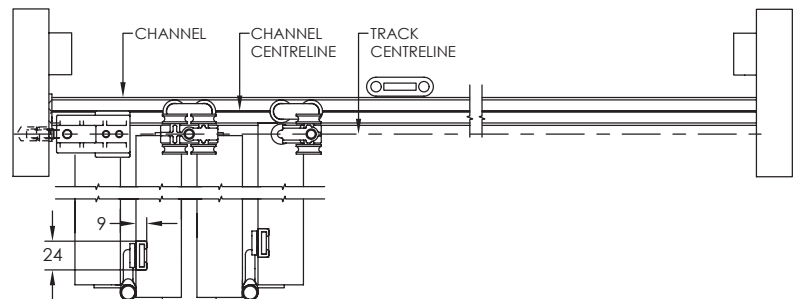

4+0 PANEL OUTWARD OPENING SYSTEM - CLOSED
(TYPICAL OUTSIDE ELEVATION)

